



DESIGN OF AUTOMATIC COMPUTER CONTROL SYSTEM FOR THE NEW UNIVERSAL TRIBOMETER UT-07

Miroslav Ravlic¹, Milan Matijevic², Branko Ivkovic³

¹PRIZMA Kragujevac, Serbia, miroslav.ravlic@prizma.co

²Mechanical Engineering Faculty, Serbia, milan.matijevic@gmail.com

³Serbian Tribology Society, Serbia, ivkovic@kg.ac.rs,

Abstract: Serbian Tribology Society and company PRIZMA Kragujevac have developed in collaboration universal tribometer UT-07, intended to perform Pin on Disc, Block on Disc (Ring), Disc on Disc and Linear reciprocating motion tribology test.

One of key features is extensive use of electronics in order to simplify mechanical design and achieve flexibility, high degree of freedom in selection of test parameters and simplicity of use.

In this paper are presented the basic informations about electronics and software part of universal tribometer UT-07.

Keywords: Tribometer, Tribology, Automatic control, Computer control, Flexible coupled drives

1. INTRODUCTION

Design of UT-07 line of tribometers is an attempt to achieve as many as possible different tribology tests (Pin on Disc, Block on Disc (Ring), Disc on Disc and Linear reciprocating motion) on one machine, instead of having different machines for each kind of tribology tests.

This approach is more economical than traditional one and with use of modern control electronics and computers it was possible to produce efficient solutions.

Main design goals for UT-07 was:

- Modular mechanical design,
- Transfer of as many as possible tasks to electronics,
- Easy to use control software,
- Open data formats.

In order to achieve universality it is crucial to have possibility of selection of mechanical parameters of tribology tests in wide range:

Speed Range for driving disk	100–4000 rpm
Sliding rate	0 – 100%
Maximum Torque	10 Nm
Load range	0 - 4000N
Contact pressure	0 – 3000 MPa
Diameter of discs	10 – 50 mm

It was challenge to achieve this design goals with as simple as possible design.

To simplify solution of control of tribometer, whole design of electronics is divided to simpler modules. Also, it is compatible with modular mechanical design of tribometer.

2. BASIC STRUCTURE OF THE UNIVERSAL TRIBOMETER UT-07

Tribometer UT-07 is designed for performing various tribology tests. Flexibility is achieved by mechanical modules for realization of various kinds of contacts (Pin on Disc, Block on Disc, Disc on Disc) and various kinds of movement in contact zone (rotational or linear).

Picture is much simpler from control point of view, because there are common tasks in almost all types of experiments:

- Speed control of driving motor,
- Speed control of breaking motor (only in Disc on Disc test),
- Control of vertical load,
- Temperature control of lubricant and lubrication of contact zone,
- Friction force measurement,
- Measurement of temperature in contact zone.

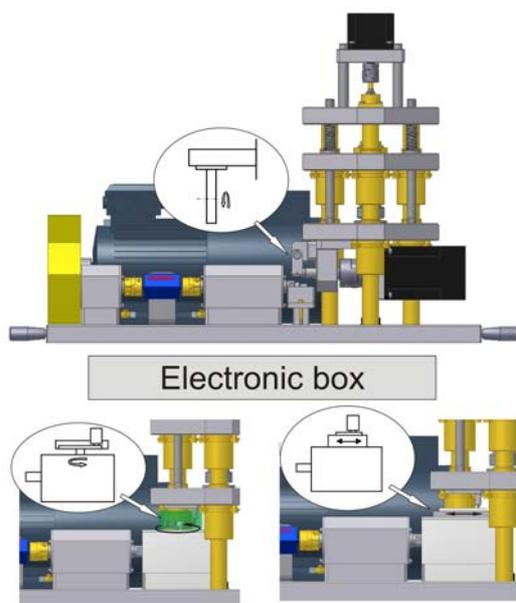

Figure 1. Possible mechanical configurations of universal tribometer UT-07.

2.1 Speed control of driving motor

Desirable speed range for driving disk was 100–4000 rpm. There are several possibilities to achieve such wide speed range. Each one has advantages and disadvantages.

First approach is to use simple AC motor and simple frequency regulator. Advantage is low cost, but drawbacks are limited range of possible speeds (1:10) and variation of speed because of varying load during experiment. In companion with mechanical gearbox it is possible to achieve speed range of 1:100. But such gearboxes are complex, expensive and prevent automatic control of speed in whole range without stopping and readjustment of machine.

Second approach is use of modern servo motors and associated regulators. With this solution it is possible to have desired speed ratio, and continuous control of speed in whole range. However, even now cost of this solution is very high.

Our approach is use of closed loop with AC motor, vector AC motor regulator and optical encoder as feedback speed sensor.

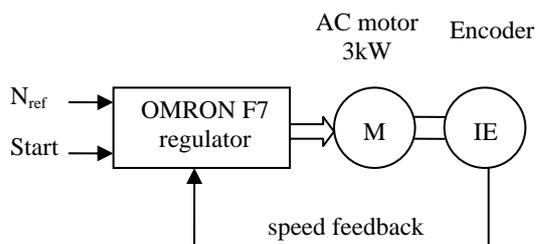

Figure 2. Block diagram of speed control of driving motor.

This approach is in between regarding performance, size and price. Reference speed is passed as analog voltage in 0-10V range to OMRON F7 vector regulator. Feedback is achieved by incremental encoder. In this approach it is possible to compensate motor slip due to load variation in whole speed range. Driving motor is grossly oversized because there is demand for high speeds, and high torques at low speeds. Size of motor is function of maximum motor current, and it is proportional to maximum motor torque. As a result, despite fact that maximum necessary driving power is less than 700W, much stronger motor is a must. Characteristics of AC motors is cooling by fan mounted on motor shaft. However, this solution is efficient only if motor is working at nominal speed. It is the reason why we mounted additional motor and fan for cooling of driving motor.

2.2 Speed control of braking motor

For Disc on Disc experiments it is necessary to control speed of driven disc. Through control of speed of driven disc it is possible to achieve various sliding rates, from almost pure sliding to pure rolling.

Main characteristics of this drive is that it must act as brake, i.e. it must dissipate mechanical power delivered by driving motor to mechanical joint of two discs.

There are several requirements specific for this drive:

- Wide range of speeds,
- Wide range of torques at all possible speeds,
- Low mass, because it is positioned on moving platform

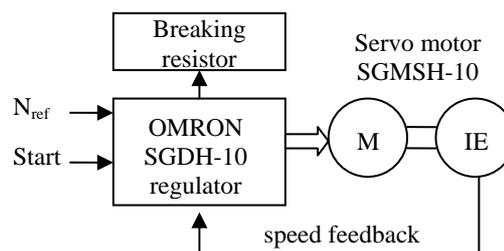

Figure 3. Block diagram of speed control of braking motor

Only one feasible solution was AC servo motor with integrated incremental encoder and appropriate regulator, despite relatively high cost.

Modern servo motors have very wide speed range and almost constant possible maximum torque at speeds from zero to maximum possible. Also, mass of modern motors is quite acceptable and they do not need additional cooling.

Because of wide range of possible speeds it is possible to mount driven disc directly on motor shaft, eliminate complex mechanics and minimize mass of whole assembly.

Reference speed for braking motor is passed as analog voltage in $-10V - +10V$ range to OMRON SGDH-10 servo regulator. Feedback is achieved by incremental encoder integrated in OMRON SGMSH-10 servo motor housing.

There were two possibilities to manage braking power. First one was recuperation of induced voltage to regulator of driving motor, and second one was dissipation on braking resistor. First approach is more economical, and does not produce additional heating inside machinery. However, because of lack of time for experiments, and lot of space for braking resistors first approach is abandoned in favor of last one. Servo regulators usually have built in braking resistors, but they are designed only for intermittent use. In tribometer there is need for constant dissipation for a long time. Because of that, inside machine is mounted heatsink with external braking resistors of 1kW capacity.

2.3 Control of vertical load

Vertical force is one of most important test parameters. Our approach is presented on figure 4.

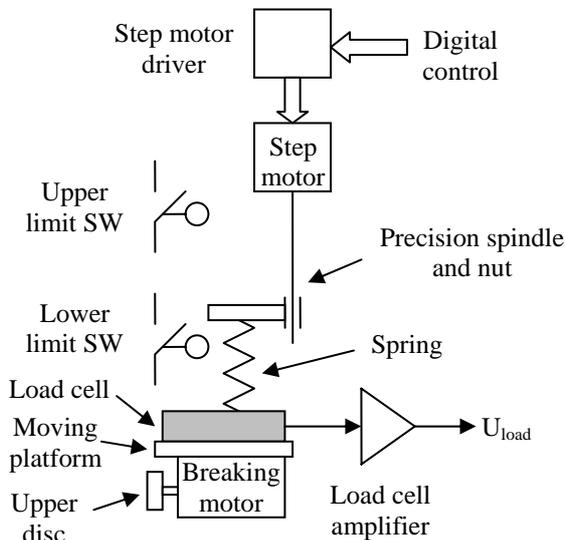

Figure 4. Block diagram of vertical force control subsystem.

Control signal from computer is amplified and passed to step motor. Step motors are very suitable for such applications because they offer high resolution (we used one with 200 steps/rev), and very easy implementation of position control in open loop.

Motor shaft is connected to spindle. Spring mounted between nut and load cell is source of vertical load. Vertical load is transmitted through

load cell to moving platform. There are additional mechanical elements for compensation of weight of moving platform in order to measure only net vertical force transmitted to test joint.

Signal from load cell is amplified by electronic amplifier and passed to data acquisition module.

There are two limit switches. Purpose of upper limit switch is positioning of moving platform at the beginning and end of experiment. Lower limit switch acts as safety device in case of failure of load cell.

Control of vertical load is achieved by rotation of step motor in CW or CCW direction. During experiment it is possible to obtain various profiles of vertical load.

One interesting side effect of our approach is possibility of indirect measurement of wear in test contact zone. If vertical load is set to constant value during time of experiment, it is possible to acquire commands sent to step motor necessary to maintain constant vertical load. During time of experiment material in contact area is subject of wearing. Result is drop of vertical load. Control system can sense this deviation and compensate for it. Step motor must make additional compression of spring. It is possible, by simple math, to calculate additional deflection of spring on the ground of acquired control issued to step motor.

2.4 Temperature control of lubricant and lubrication of contact zone

Subsystem for lubrication and temperature control of lubricant is of very simple structure.

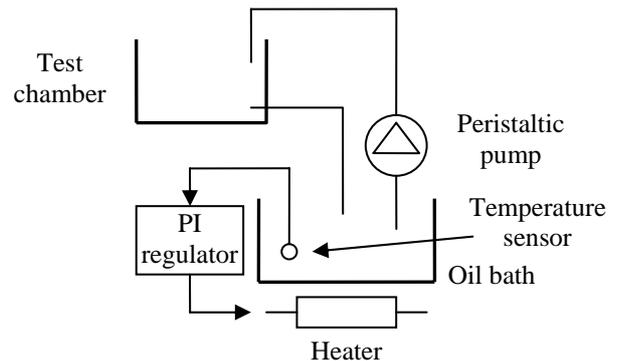

Figure 5. Block diagram of lubrication subsystem.

Oil bath is mounted on electric heater. There is separate PI regulator for temperature control of lubricant in oil bath. User can directly enter desired value for temperature of lubricant into PI regulator. It is possible only to heat up lubricant, i.e. there is no possibility to cool down lubricant, as can be necessary in hot environment or during some harsh tests.

Peristaltic pump maintains constant flow of lubricant from oil bath to test chamber and lubrication of test zone.

2.5 Friction force measurement

Friction force is measured indirectly. There is contactless torque sensor mounted between driving motor and lower disc.

Measuring of torque this way is very convenient because modern sensors require only DC supply, have integrated electronics for bridge excitation, contactless transmission of power and signal between rotor and stator part and analog output proportional to measured torque.

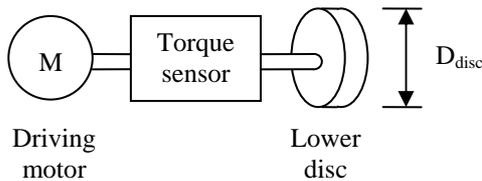

Figure 6. Block diagram of friction force measurement.

Calculation of friction force sensed by sensor is straightforward if diameter of lower disc is known.

Disadvantage of this approach is that torque sensed by sensor contains two component: one proportional to friction force in contact zone and another whose source are losses in transmission train between torque sensor and test contact. In case of Disc on Disc and Pin on Disc tests transmission losses are small, because there is only one ball bearing after torque sensor. However, in case of reciprocating linear motion where much more complex transmission train is necessary it is must to take in account additional losses. The only possible way is open loop compensation of losses through software. Measurements of mechanical losses on various regimes during calibration of machine are performed, and measured values are stored into software for future compensation of measurement.



Figure 7. Mounted torque transducer.

2.6 Measurement of temperature in contact zone

Beside forces in contact zone there is interest in measuring temperature in contact zone. There are two sensor: one contact thermocouple sensor and one IR contactless sensor.

With thermocouple sensor it is possible to measure temperature inside test item (during Pin on Disc or Block on Disc tests) or temperature of lubricant inside test chamber.

IR sensor is devised for contactless monitoring of temperature in contact zone. However, variation of reflection coefficient of various materials and lubricants and relatively wide angle of view of sensor itself do not permit precision absolute measurement of temperature in contact zone, but comparative measurements only.

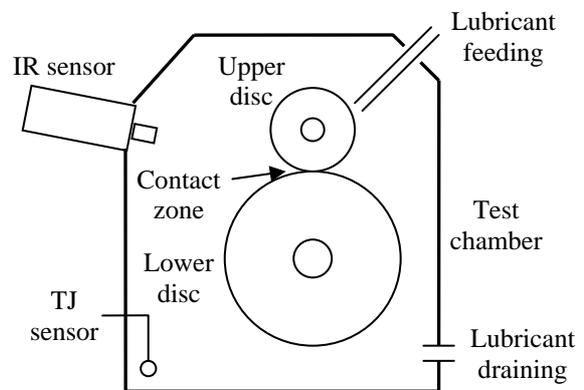

Figure 8. Sketch of test chamber

2.7 Data acquisition subsystem

USB module DT9802 acts as data acquisition subsystem. Module has 16 single ended analog inputs, 2 analog outputs, 8 digital inputs and 8 digital outputs. All analog lines have 12 bit resolution, and all digital lines are TTL compatible. It is interfaced to PC via USB connection.

Because all subsystems of UT-07 have separate local regulators there are no stringent requirements for timing in data acquisition subsystem. Role of data acquisition module is to set reference values for speed regulators, set control for step motor and acquire signals from sensors. Tribology tests are slow varying processes, so even simple USB modules can satisfy requirements. USB interface is now de facto standard for PC interfacing and replaces obsolete serial and parallel interfaces.

Additional advantage of USB module is that it is powered from USB port, i.e. there is no need for another +5VDC power supply.

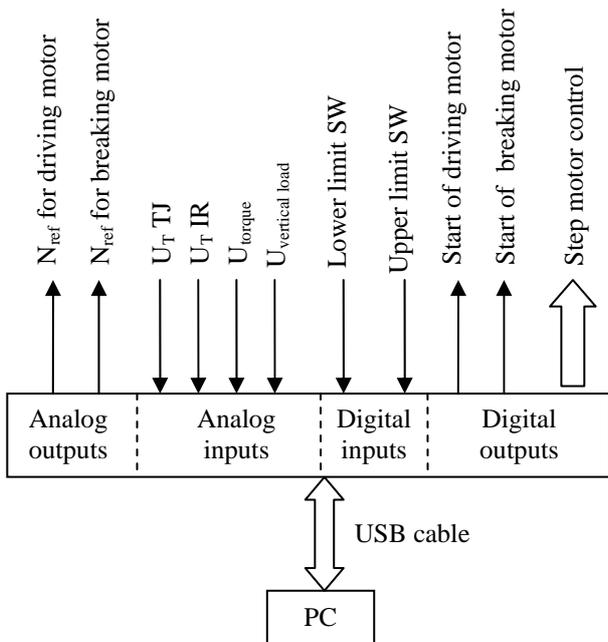

Figure 9. Block diagram of data acquisition subsystem.



Figure 10. Photo of UT-07 with open electronics compartment

2.8 Software support

Electronics inside has no any intelligence. So all software is located inside personal computer

Purpose of software is

- Collection of data from tribometer during experiments,
- Observation of the measured values collected in real time during experiments,
- Creation of text data files with collected data and
- Observation and printing of previously measured data.

Software is working under MS Windows XP operating system which is not intended for real time applications. However, thanks of internal structure of UT-07 (local hardware regulators) and low speed of processes inside UT-07 it is possible to use MS Windows.

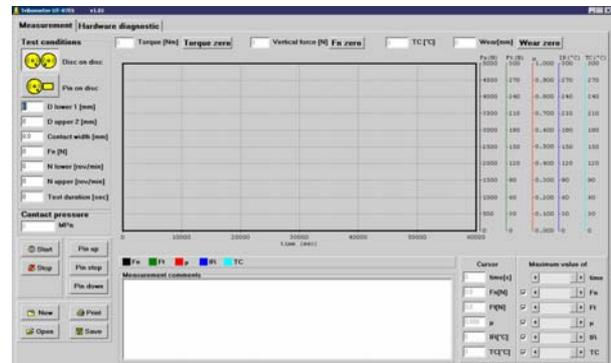

Figure 11. Startup screen

Before start of experiment it is possible to set machine configuration, parameters of experiment and comments associated with experiment.

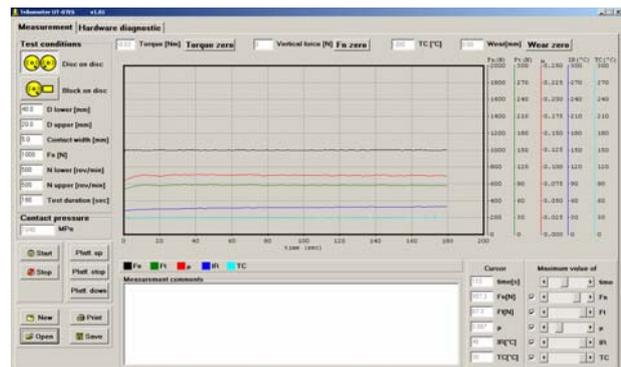

Figure 12. Screen with captured data

After an experiment it is possible to save or print acquired data. Program allows drawing and printing all or just portion of collected data. Acquired data can be stored on computer disc file.

Program use plain ASCII text files for storing of data, no proprietary binary formats. Therefore, it is easy to import collected data to some other program for further processing.

Also, it is possible to print collected data to laser or some other MS Windows supported black/white or color printer.

Program allows importing of multiple saved data files. This way user can simple compare measured data from multiple experiments and deduce influence of experiment parameters and conditions to final results.

Beside measurement, program allows diagnosis of hardware inside UT-07. It is possible to see voltages present on analog inputs, to set voltages on analog outputs, to see state of digital inputs and to set state of digital outputs. This way it is possible to

isolate fault to some of subsystems inside UT-07 and make repair easier.

3. CONCLUSION

The universal UT-07 tribometer can perform many types of tribological tests. It is possible because of its modular and adaptive mechanical design and extensive use of electronics and computer control.

In all stages of design intention was to achieve maximum possible performances with as low as possible cost of equipment, but without compromising performance.

Use of personal computer and software allow easy handling of instrument and conducting of experiments.

REFERENCES

- [1] Yaskawa - F7 Drive User Manual.
- [2] Yaskawa - Sigma II Series Servo System Drive User's Manual
- [3] Omega - OS100 SERIES Mini-Infrared Transmitter.
- [4] Isel - Catalog data for MS300HT step motor.
- [5] Interface - Operation Manual for Type T8 LC Rotary Torque Transducer
- [6] Interface - Model SGA Strain Gauge Transducer Amplifier User's Guide.

UT-07ES - Experimental results

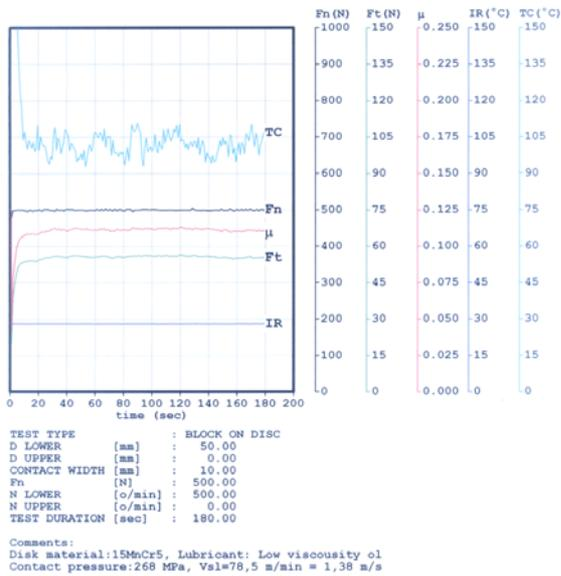

Figure 13. Example of results obtained in the Block-on-Disc test.

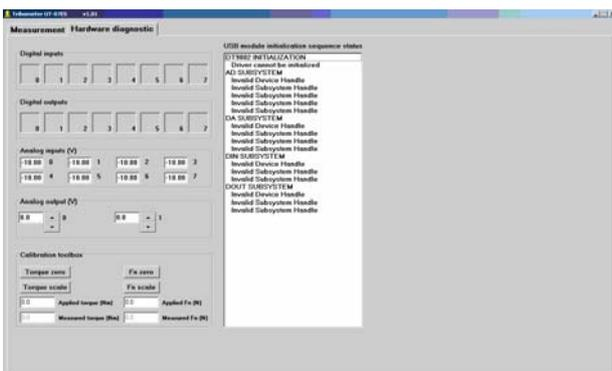

Figure 14. Hardware diagnostic screen