



Serbian Tribology  
Society

# SERBIATRIB '13

13<sup>th</sup> International Conference on  
Tribology



Faculty of Engineering  
in Kragujevac

Kragujevac, Serbia, 15 – 17 May 2013

## TRIBOLOGY ASPECT OF RUBBER SHOCK ABSORBERS DEVELOPMENT

Milan Banić<sup>1</sup>, Dušan Stamenković<sup>2</sup>, Miloš Milošević<sup>3</sup>, Aleksandar Miltenović<sup>4</sup>

<sup>1</sup>Faculty of Mechanical Engineering, University of Niš, Serbia, banic@masfak.ni.ac.rs

<sup>2</sup>Faculty of Mechanical Engineering, University of Niš, Serbia, dusans@masfak.ni.ac.rs

<sup>3</sup>Faculty of Mechanical Engineering, University of Niš, Serbia, mmilos@masfak.ni.ac.rs

<sup>4</sup>Faculty of Mechanical Engineering, University of Niš, Serbia, amiltenovic@yahoo.com

**Abstract:** *Rubber is a very flexible material with many desirable properties which enable its broad use in engineering practice. Rubber or rubber-metal springs are widely used as anti-vibration or anti-shock components in technical systems. Rubber-metal springs are usually realized as a bonded assembly, however especially in shock absorbers, it is possible to realize free contacts between rubber and metal parts. In previous authors research it was observed that friction between rubber and metal in such case have a significant influence on the damping characteristics of shock absorber. This paper analyzes the development process of rubber or rubber-metal shock absorbers realized with free contacts between the constitutive parts, starting from the design, construction, testing and operation, with special emphasis on the development of rubber-metal springs for the buffing and draw gear of railway vehicles.*

**Keywords:** *rubber friction, rubber-metal spring, shock absorber, product development.*

### 1. INTRODUCTION

Rubber or rubber-metal springs are widely used in industry as anti-vibration or anti-shock components giving many years of service. They have several advantages in respect to metal springs (lower price, easier installation, lower mass, reduced corrosion, no risk of fracture and no need for lubrication) [1]. However, they have one major disadvantage reflected in insufficiently reliable service life caused by rubber fatigue.

Those elements are well established to control vertical and lateral movements. Nowadays, the more demanding operating environment has made the design of such components more challenging than ever before. In addition to the design of the rubber part itself the interface between the part and the structure is also important.

The properties of the rubber-metal spring are mainly influenced by a rubber compound. Rubber compounds are generally composed of a base rubber (e.g. natural rubber), filler (e.g. carbon black) and a curing agent (e.g. sulphur). Additional components may include antioxidants, adhesion agents, flame retardant agents and special process-

enhancing chemical additives. Common physical properties of rubber compounds are affected by every ingredient of a rubber recipe independently of or dependently on each other. The mixing and curing process is also critical in determining these properties. Improving one compound property always results in changing other properties, for better or for worse. Noted fact makes development of elastomeric based products a very complicated task. Up to appearance of modern computer aided tools, the development of those products relied only on previous experience of the designer and trial and error procedure. Such approach was inefficient, expensive and time consuming because it required iterative procedure combined with excessive experimental testing to achieve desired mechanical properties.

Rubber-metal springs are usually realized as a bonded assembly, however especially in shock absorbers, it is possible to realize free contacts between rubber and metal parts. In that case, connections between rubber blocks and metal plates are realized by applying pressure and resulting static friction. During the load cycle of the shock absorber, apart the energy dissipation in rubber,

additional energy is dissipated due to friction between rubber and metal parts.

In previous authors research [2] it was observed that friction between rubber and metal in such case have a significant influence on the damping characteristics of shock absorber. This paper analyzes the development process of rubber or rubber-metal shock absorbers realized with free contacts between the constitutive parts, starting from the design, construction, testing and operation, with special emphasis on the development of rubber-metal springs for the buffing and draw gear of railway vehicles.

## 2. DEVELOPMENT OF THE RUBBER-METAL SHOCK ABSORBER

With appearance of modern computer tools and virtual product development, the development process of shock absorbers became more efficient due to simulated experimental testing of virtual prototype. With virtual product development tools it is possible to predict the absorbing capacity and service life before the manufacturing of the product prototype which was not possible in classical development process.

The assembly of shock absorber with rubber-metal spring usually consists of a few rubber-metal elements separated with metal plates and prestressed with a central screw. A rubber-metal element represents a metal carrier in the shape of a circular plate with natural or synthetic rubber vulcanized on both sides. Therefore, the advantages of both component elements are involved: high abilities of displacement and amortization of rubber and large loads which are sustained by metal parts. These ensure the decrease of noise and amortization of impact loads. Figure 1 shows the design of buffing gear spring assembly, while Figure 2 shows the design of draw gear spring assembly.



**Figure 1.** Rubber-metal spring assembly of buffing gear



**Figure 2.** Rubber-metal spring assembly of draw gear

As already noted, these springs are used as anti-shock components, so the main properties designer must take into account are absorbing capacity and stiffness of the spring. The most important absorbing characteristic of rubber is evaluated by its hysteresis. Hysteresis is the mechanical energy loss that always occurs in an elastic material between the application and the removal of a load. If the displacement of a system with hysteresis is plotted on a graph against the applied force, the resulting curve is in the form of a loop. It depends not only on the elastomer type, but also on fillers and other compound ingredients as other mechanical properties.

The authors defined a virtual product development procedure (Figure 3) for development of rubber-metal springs used in shock absorbers. The development procedure is based on application of modern viscoplastic rubber constitutive model (Bergström-Boyce), which besides higher accuracy of prediction, enables the assessment rubber compound hysteresis and strain rate dependence which is not possible by application of hyperelastic models usual for rubber FE analysis. The parameters of rubber constitutive model (Bergström-Boyce) are determined by uniaxial compression at different strain rates and stress relaxation test on the samples of the rubber compound ( $\varnothing 35.7 \times 17.8$  mm) [3]. The samples are compressed between hardened steel plates lubricated with machine oil in order to prevent the barrelling of samples. Based on the performed experiments, the database of model parameters for the rubber compounds can be defined. Database also contains data about other significant properties of rubber compound, such as composition, common mechanical properties, etc.

The first step in procedure shown at Figure 3 is to determine the rubber compound for rubber-metal spring. From the formed database several compounds are selected based on criteria defined by widely known selection and service guide for elastomers [4] regarding the product specific requirements (creep, low-temp stiffening, heat aging,...) and the operating environment conditions (resistance to ozone, radiation, ...). The selected

compounds are used for simulation of static and dynamic hysteresis of standardised specimens.

The simulation of static hysteresis test is conducted on cylindrical test samples ( $\varnothing 35.7 \times 17.8$  mm), according to the internal standard SIMF.92.006 [5]. The simulation dynamic hysteresis (Yerzley hysteresis) test is carried out on cylindrical test samples ( $\varnothing 19.5 \times 12.5$  mm) according to the standard ASTM D 945-06 [6].

The obtained results of static and dynamic hysteresis are used for final selection of rubber compound. As the main feature and an indicator of the quality of rubber-metal springs is energy absorption capacity, the compound is selected based on criterion of highest static and dynamic hysteresis obtained during simulation.

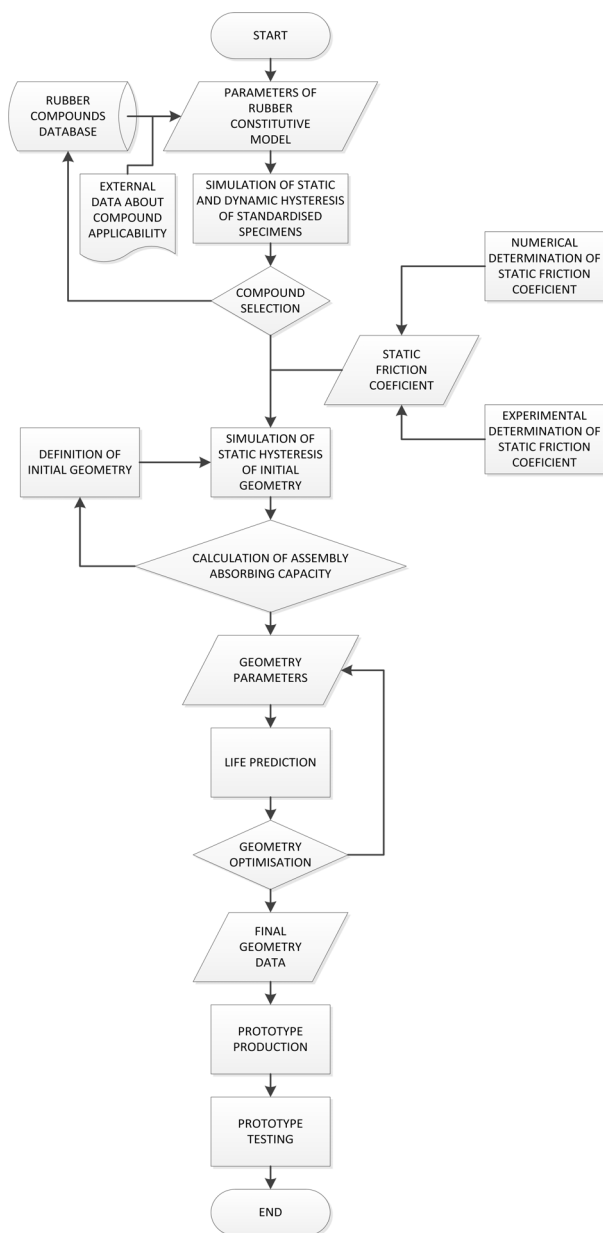

**Figure 3.** Procedure for development of shock absorbers with rubber-metal spring

The next step following the adoption of the rubber compound is the selection of the appropriate structural design of the basic rubber metal element and their combination into a spring package. As already noted, the main problem in developing rubber-metal springs is that a designer cannot estimate how many basic rubber metal spring elements need be combined in a serial set to achieve the required absorption capacity. The amortizing ability of a rubber-metal spring package, and therefore the constitutive number of basic rubber metal elements, should be determined by simulation using the finite element method. Based on the required operating stroke, built-in measures and assumptions about preloading of rubber-metal spring the initial design of the basic rubber metal elements is adopted. For instance, the initial geometry of the basic element of buffer rubber-metal spring is shown on Figure 4. It consisted of a metal disk with openings and vulcanized rubber parts on both sides of the plate connected through the plate's openings (Figure 4).

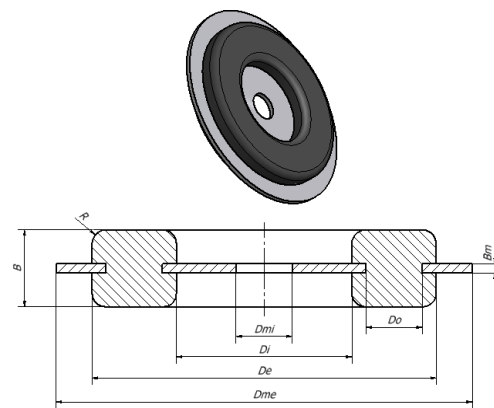

**Figure 4.** The basic rubber metal spring element of buffing gear

Upon the simulation of static hysteresis of basic element, the number of elements in rubber-metal assembly can be easily determined as the ratio of required spring absorption capacity and the absorption capacity of the single element. The procedure is sometimes iterative to obtain desired results with required value of normal reaction force during impact and limited number of basic elements due to installation requirements.

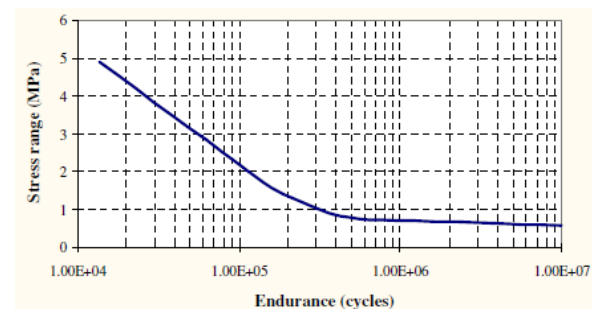

**Figure 5.** S-N curves of the rubber-metal element [7]

The adopted geometry parameters are further improved by optimisation. The optimization procedure is performed in order to improve the design of the spring element regarding its service life. By lowering the element stress levels values, the service life is prolonged which is obvious from Figure 5. As an example, the optimisation basic rubber metal spring element of buffering gear is performed by defining the design of experiment as a central composite design in simulation. By variation of the plate opening diameter ( $D_o$ ), the number of openings ( $B_o$ ) and radius on top and bottom of the rubber part of the element ( $R$ ), the functional dependence of maximum equivalent stress from input parameters was obtained. Minimisation of the obtained functional dependence results in optimal geometric dimensions of the basic spring element. The functional dependence of maximal equivalent stress from input parameters is shown in Figure 6.

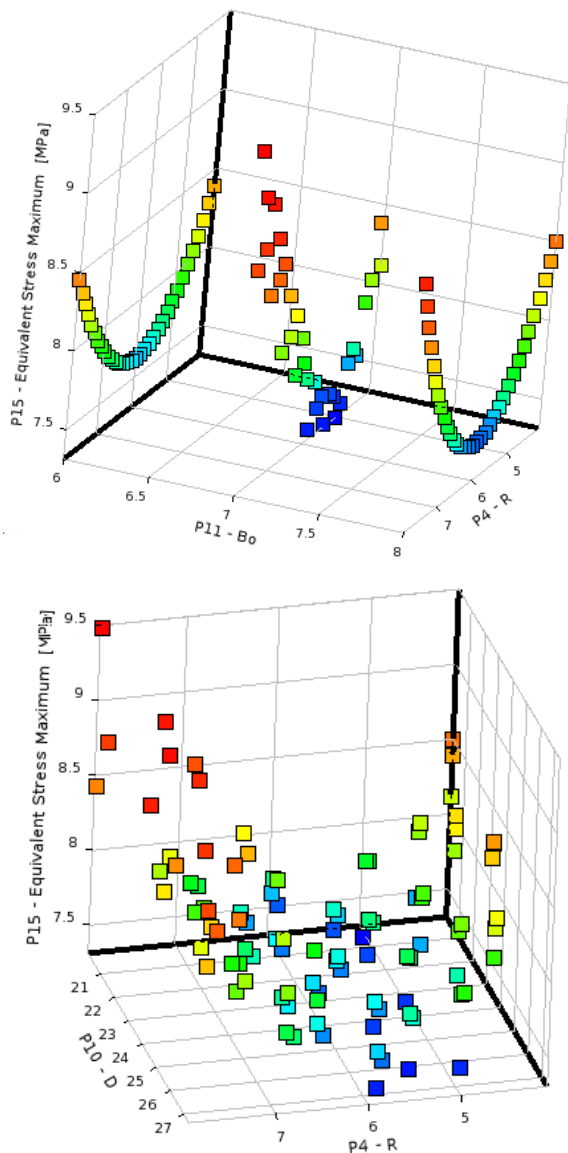
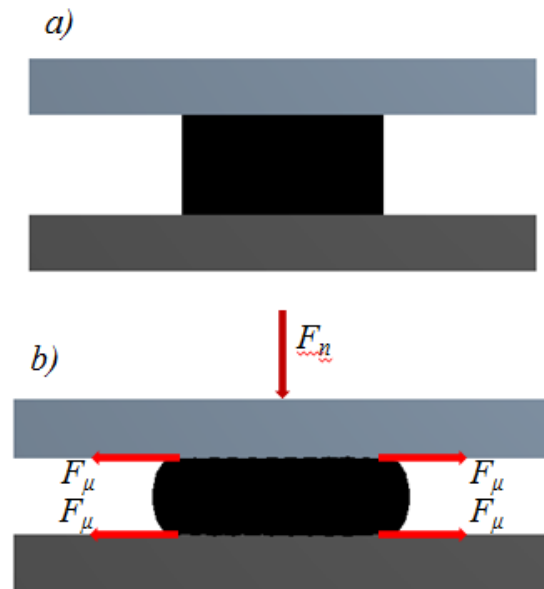

**Figure 6.** Functional dependence of maximal equivalent stress from the optimisation parameters

Upon the definition of final geometry of the element, the actual production and testing of prototype are performed in order to validate design and to determine the accordance with the design requirements.

### 3. TRIBOLOGY ASPECT OF THE SHOCK ABSORBER DEVELOPMENT

Rubber has a very high coefficient of friction which can even reach value of  $\mu = 4$ . High friction coefficient, and thus high grip of rubber, found its way in many engineering applications; for example, rubber is not always bonded in bushes, since its frictional grip is almost equal to a bond. During the load of unbounded rubber metal assembly in compression the friction force occurs (Figure 7). Due to high grip between the rubber and the metal the rubber is barrelling thus increasing the contact surface.



**Figure 7.** Compression of rubber between steel plates: a) unloaded; b) loaded

It has been noticed that the amount of the accumulated/absorbed energies of rubber-metal springs loaded in compression greatly depends on the contact between the rubber and the metal [2].

Noted findings were also confirmed by other authors. For instance, Figure 8 shows the effect of lubricating the contact between rubber and metal in compression. Provided that the steel ends are clean the grip is almost equal to that of a bonded sample.

Although bonded contact provides a higher normal reaction force during impact, the free contact such as in draw and buffer gear rubber metal spring assembly dissipates more energy as there are friction induced energy losses due to contact sliding. If the friction coefficient is sufficiently high to ensure that significant sliding

between metal and rubber will not occur shock absorber will have better absorbing properties.

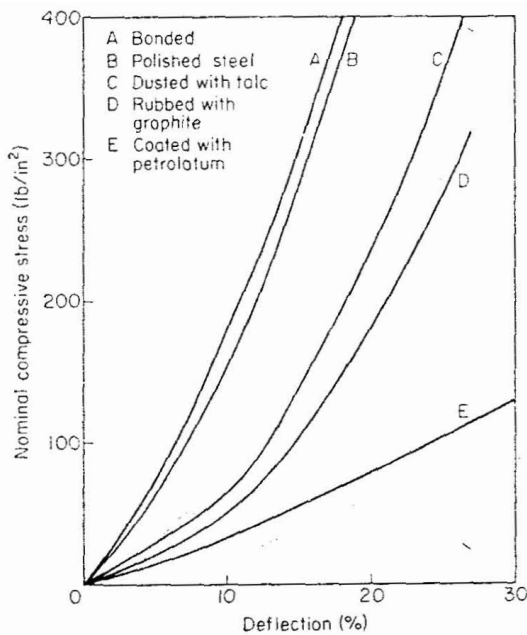

**Figure 8.** Effects of surface conditions on the stress/deflection curve for rubber under compression [8]

Significant sliding compromises the assembly stability and has a great effect on lowering of normal resulting force. Furthermore, the increase of the friction coefficient on the contact surfaces of the rubber element increases the shear stress and its share of the total stress also. The increasing shear stress further increases the total stress in the element and the force which resists the deformation of the element. The increase of the shear stress share of the total stress leads to the enhanced amortization capacity of rubber elements. As the high values of normal resulting force are the design requirement, it is necessary to find the balance between the sliding allowance and resulting normal force. It can be achieved by influencing the tribological contact parameters (lubrication, surface roughness of the metal part, contact pressure, ...) and thus the friction coefficient value.

Based on above it can be concluded that it is not possible to actually perform the virtual development process of the shock absorber with rubber metal spring without the knowledge of the friction coefficient value in contact between the rubber and metal parts.

The coefficient of friction of rubber is highly dependent on contact pressure. As the contact pressure between the rubber and the free metal plates in shock absorbers is approximately 20 MPa, it is extremely difficult or even impossible to experimentally determine the actual value of friction coefficient at noted operating contact pressure.

The compound friction coefficient can be predicted based on experiments with rubber specimens or based on existing data on normal reaction force in similar operating conditions. By simulation of experiments on rubber specimens or previously performed experiments, the friction coefficient can be determined by goal driven optimisation procedure. The value of friction coefficient will be approximately determined when the normal reaction force obtained by simulation is equal to experimentally obtained one.

As an example, it is necessary to determine the friction coefficient in contact between rubber with trade name TG-B-712 (manufactured by company TIGAR, Pirot) and metal plate at contact pressure of 3 MPa. The rubber specimen (with dimensions  $\varnothing 35.7 \times 17.8$  mm) was compressed between steel plates at specific tribological conditions for which it was necessary to determine the value of friction coefficient. The force-displacement data was recorded during the experiment (Figure 9).

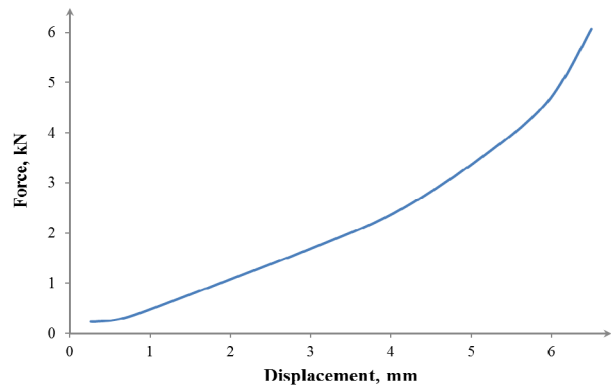

**Figure 9.** Experimental force – displacement data

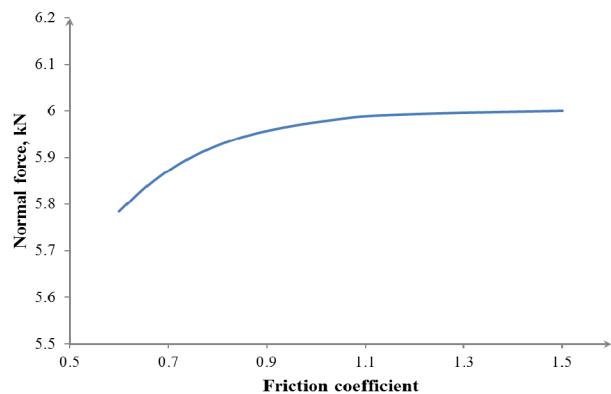

**Figure 10.** Functional dependence between friction coefficient and force determined by virtual experiment

The friction coefficient was determined by virtual experiment from which the functional dependence between friction coefficient and normal resulting force was obtained (Figure 10). Based on realistic experimental data (Figure 9) it is clear that the maximal resulting normal force correspond to friction coefficient value of  $\mu = 1.5$ .

#### 4. CONCLUSION

Tools of virtual product development enable significant cost and time savings in the process of development of shock absorbers filled with rubber-metal springs.

But to employ the tools of virtual product development it is essential to have a value of friction coefficient in free contact between rubber and metal parts. Without the correct value of friction coefficient the proposed procedure outlined in the paper would provide incorrect data which is not suitable for shock absorber development process.

As experimental determination of friction coefficient in contact between rubber and metal at high values of contact pressure can be very problematic, the friction coefficient can be estimated by goal driven optimisation during numerical simulation of realistic experiments with existing resulting force data.

#### REFERENCES

- [1] V. Miltenović: *Mašinski elementi-oblici, proračun, primena*, Mašinski fakultet Univerziteta u Nišu, 2009.
- [2] D. Stamenković, M. Milošević: Friction at Rubber-Metal Springs, *11<sup>th</sup> International Conference on Tribology - SERBIATRIB '09*, 13-15.05.2009, Belgrade, pp. 215-219.
- [3] M. Banić, *et al.*: *Prediction of Heat Generation in Rubber or Rubber-Metal Springs*, Thermal Science, 16 (Suppl. 2), pp. 593-606, 2012.
- [4] ...:Vibration & motion control catalogue, LORD Corporation, 2008.
- [5] SIMF.92.006.
- [6] ASTM D 945 Standard Test Methods for Rubber Properties in Compression or Shear.
- [7] R. K. Luo, W. X. Wu, P. W. Cook, W.J. Mortel: *Fatigue design of rubber springs used in rail vehicle suspensions*, Proceedings of the Institution of Mechanical Engineers, Part F: Journal of Rail and Rapid Transit, 217/3, pp. 237-240, 2003.
- [8] A. B. Davey, A. R. Payne: *Rubber in engineering practice*, Great Britain, 1964.