

## INFLUENCE OF ADDITIVES AND SELECTIVE TRANSFER ON WEAR REDUCTION IN THE LUBRICATED CONTACT

Mara Kandeва<sup>1</sup>, Boryana Ivanova<sup>1</sup>, Emilia Assenova<sup>2</sup>, Aleksandar Venc<sup>3</sup>

<sup>1</sup> Faculty of Industrial Technologies, Technical University – Sofia, Boulevard Kliment Ohridski 8, 1156 Sofia, Bulgaria; kandevam@gmail.com; bsaykova@tu-sofia.bg

<sup>2</sup> Society of Bulgarian Tribologists, Boulevard Kliment Ohridski 8, 1156 Sofia, Bulgaria; emiass@abv.bg

<sup>3</sup> Faculty of Mechanical Engineering, University of Belgrade, Kraljice Marije 16, 11120 Belgrade 35, Serbia; avenc@mas.bg.ac.rs

*Rewiev paper / Pregledni rad*

### Abstract

Tribology has always been at center of the efforts to increase reliability and quality, to reduce maintenance costs and to extend the service life of technical systems. The continuous improvement and advance technology of machines necessitate higher quality of lubricants and lubrication technologies, which influences equipment life and environment protection. This paper seeks to bind down tribology, reliability, quality and safety in the application of lubricants with additives, aiming wear prevention, based on specific examples with one of the newest oil-soluble metal-plating composite additive called “Valena”.

**Keywords:** Oil-soluble additives, wear, selective material transfer.

## INTRODUCTION

The continuous improvement and advance technology of machines necessitate higher quality of lubricants and lubrication technologies, which influences equipment life and environment. Being a working medium in the contact systems, lubricants reduce friction and wear replacing the external dry friction between contact surfaces by internal friction in the lubricant.

The authors draw attention to the phenomenon of self-organization during selective transfer of material between contact surfaces during the formation of a frictional coating on the surfaces, initially studied by D.N. Garkunov, G. Polzer, V. Babel, R. Marczak, etc. [1-4]. Characteristic for the process of selective transfer of material between frictional surfaces is the formation of secondary layer with low shift resistance. This protective layer cannot accumulate dislocations and is highly antifrictional. The self-organization phenomena in this case depend on the interface energy and the material exchange. That is why generation of that layer requires particular combination of materials of the contact surfaces, as well as special lubricant between them.

Repair-regeneration oil additives have an important place in the application of lubricants. Added to oils or greases they assure partial regeneration of worn surfaces under special friction conditions. Forming an antifrictional protective layer during a selective transfer between the working surfaces, they decrease friction and wear, and increase the wear-resistance in the contact pairs of machines. Most common are the organic oil-soluble additives [1,5,6].

The influence of one of the newest additives, the oil-soluble metal-plating composite additive called "Valena", developed in Russia and manufactured by the company "Rudservice" from Kazakhstan, on friction and wear parameters of contact pairs lubricated by oils and greases, and the formation of frictional coating in the process of selective material transfer have been investigated by the authors. An illustration of the influence of this additive is given through the study of high strength cast iron specimens lubricated with transmission oil with and without additive.

### *Tribology – the science of contact*

The study of friction, wear, and lubrication has been of enormous practical importance for a long time, since the functioning of many mechanical, electrical and biological systems depends on the appropriate friction and wear processes. In recent four decades, this field, termed **tribology** [7,8], has received increasing attention as it is now evident that the wastage of resources resulting from high friction and wear is, for example, greater than 6% of USA GNP. Focusing on fundamental concepts such as surface energy, deformation, microfracture, and surface interactions at the mezo-, micro- and nano-scale, the application of fundamental knowledge to control friction and wear behaviour through lubrication and selection of materials and coatings in practical situations, can help to meet a part of modern scientific and practical demands.

The importance of environmental engineering through sustainable tribology solutions in our epoch should show that sustainability can be achieved, to a significant extent, through environmental friendly engineering solutions stimulating sustainable development and providing stability to our world. Green tribology (the science of the tribological aspects of ecological balance and of environmental impacts, known formerly as ecotribology [9-12]) is expected to directly affect the nations, reducing waste, noise and thermal pollution, and extending equipment reliability and life, reducing the material and heat pollution of production systems, improving thus the quality of life, problems which are some of the key challenges facing the societies today. One of the green tribology tasks is related to wear diminution or, where possible, avoiding wear.

### *Wear prevention*

Various reasons and causes can make machines and equipment break-down, and usually the starting place of the problem are the tribological components (components with surfaces in contact), i.e. bearings, gears, seals, couplings, surfaces contacting with heavy loads and destructive media. Tribological knowledge helps to reveal and heal wear related problems. So, it is possible to improve quality significantly by measures preventing the reasons for failures caused by wear of contacting surfaces.

Wear is a process of tribological interaction resulting in physico-chemical loss of material (weight, size or shape) from the surfaces in contact. Most important types of wear are abrasive, adhesive, pitting, erosive, fretting, cavitation, corrosive, etc. [13-15]. Measures for minimizing wear are connected to surface processing, namely optimal material selection and surface texturing, coating the surfaces and, the most popular measure, **lubrication**. It leads to good health and preservation of performance quality of machines, equipment and production systems, and hence, material, energy and environment saving as a whole.

### *Lubrication and lubricants*

Lubrication is the process, or technique employed to reduce wear of two surfaces in close proximity (in contact), and moving relative to each other, by interposing a substance called lubricant between the surfaces. The interposed lubricant film can be a solid (e.g. graphite, MoS<sub>2</sub>), a solid/liquid dispersion, a liquid, a liquid-liquid dispersion (e.g. grease) or a gas.

As the mechanical stress increases on the contacting surfaces, three regimes of lubrication can be observed (Figure 1): fluid film (elastohydrodynamic and hydrodynamic lubrication - (E)HL, mixed lubrication - ML, boundary film lubrication - BL.

A question of huge importance of applying tribology is the development and creation of higher quality of lubricants and additives to them, which influence equipment reliability and life, energy and raw material savings, as well

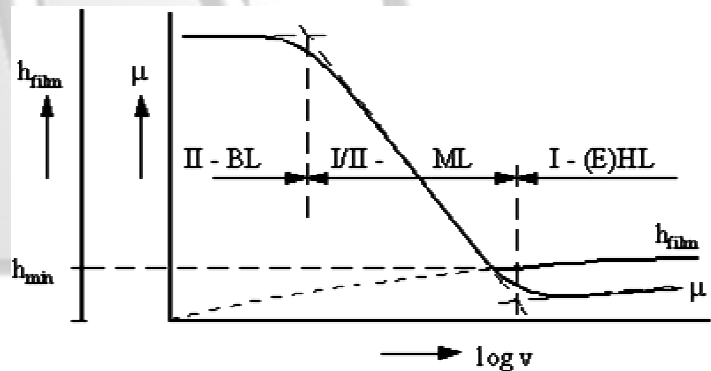

**Figure 1. Stribeck curve and lubrication modes**

as provide safety solutions to many environmental tasks. The continually increasing equipment temperatures and loading, and enlarged demands on lubricant life and operation, as well as the larger demands directed to ecological sustainability, raise many questions to modern lubricants, lubricant technology and their future applications over the next years [16-19].

### **BASESTOCK AND ADDITIVES**

The base stock oil is refined mineral oil that contains no additives. Higher requirements for thermo-oxidative stability, longer fluid life and higher thermal, mechanical and tribological loads on lubricants are projected for the future. The demand for high-quality base oils with low viscosity is more and more increasing [15,18,20-22]. There are combinations between additives and base

oils that are yet to be exploited. Traditional additives (extreme pressure, antiwear, dispersants, antioxidants) have to comply with improved stability and calculated decomposition between surfaces and bulk phases.

The development of commercially workable green additives is an obvious need that could expand the current market for biobased and biodegradable lubricants [23,24]. Nanoparticle-based lubricant additives (mostly boron or carbon) that can compete with traditional additives are also being developed. These additives interact with the contact surface to produce a low friction protective film. They significantly improve protection against micropitting, and can drastically lower friction and wear in industrial and motor vehicle applications. Since they substitute sulfur- and phosphorous-containing additives, nano-based additives reduce environmentally hazardous emissions [18].

#### *Effect of the metal-plating additives on lubricating oil*

Lubricating oil service life mainly depends on its antioxidant property, i.e. its resistance to changes of physical-chemical and service properties during operation and storage. Lubricating oil antioxidant stability is one of the most important properties determining its service period: the less stability, the more often the oil should be changed during operation. Metal-plating lubricants are used to improve the antioxidant stability of lubricants.

The term *metal-plating lubricant* appeared in 1962 in connection with the invention by D.N. Garkunov in Russia, about a lubricant capable of realization of selective transfer of material between the contacting surfaces [1]. The development continued with the work of prof. V. Babel, prof. G. Polzer, prof. R. Marczak, etc., researchers in the field of selective transfer [18,19,21,22]. This class of lubricants contains 0.1 to 3 % of additives: metal powders, alloys and oxides, salts and metal-organic complexes, so-called metal-plating additives. The metal-plating lubricant assists to the realization of selective transfer, as result of which a friction surface film is formed that is subjected to small oxidation. The film is formed of metal atoms introduced in the contact zone with the lubricant, varying from several atom layers to 2 – 4  $\mu\text{m}$  film.

Metal-plating lubricants are employed for heavy-loaded friction couples in machines, airplanes, cars, etc. Their use doubles or triples durability of the contact pair, makes decrease of friction losses and lubricants costs by two times, and promotes machine efficiency. Mostly applied are metal-plating lubricants that form copper, tin and lead films on the frictional surfaces. The metal-plating additive application has been mostly realized in Russia, Germany and Poland, and several other countries [1-3,6,25].

#### *Frictional coatings*

D.N. Garkunov and G. Polzer are of the first researchers in theory and practice of the selective transfer of material during friction, and the formation of the so-called frictional coatings. Common works were carried out between the Tribology Center in Sofia and the Tribology Group of prof. Polzer in Zwickau, and recently in Schoenfels, Germany [1-4].

The element to be coated is subjected to rotation and to the pressure of the brass stick in the presence of a special lubricant, mostly glycerol. Selective transfer is induced during the friction process and copper is deposited frictionally on the shaft after the self-formation of a non-oxidizing copper film. Thin copper films are formed after selective transfer of copper on the frictional surfaces. As a result of the frictional deposition, a tribological system appears which can carry higher loads at the influence of various processes. Material exchange in the system brass-glycerol-

steel is observed and the obtained film is a coat with significant change of wear-resistance. The self-organization phenomena in this case depend on the interface energy and the material exchange. That is why generation of that layer requires particular combination of materials of the contact surfaces, as well as special lubricant between them.

Important features of the coating deposited during friction under selective material transfer mode are: low wear of components at nonabrasive treatment of steel/cast iron and lower inclination for welding and seizure between the friction surfaces. Significant is also the reduction of the concentration of hydrogen at the frictional surface and, respectively, the lower hydrogen wear. It is highly important for practical applications that the inclination for welding and seizure between the friction surfaces is significantly lowered under conditions of selective transfer. A considerable practical result is the possibility for dismantling-free restoration of worn units/couples.

Frictional coating formation is also observed in the cases where repair-regeneration oil additives are added to oils and greases. Added to lubricant these additives assure partial regeneration of the worn surfaces under special friction conditions. At the same time, they decrease friction and wear in the contact pairs of machines. Most familiar are the organic oil-soluble additives. Special attention in this paper is given to the application of *Valena* oil-soluble additive.

#### *Valena additive*

This paper focuses on the study of one of the newest additives, the oil-soluble metal-plating composite additive called "Valena", manufactured by the company "Rudservice" from Kazakhstan [6]. The influence of this additive on the friction parameters of contact pairs lubricated by oils and greases, and the formation of frictional coating in the process of selective material transfer in the working contact, was the subject of investigation in the Tribology Laboratories at Faculty of Industrial Engineering, Technical University Sofia and Faculty of Mechanical Engineering, University of Belgrade [5]. In this research, the influence of "Valena" metal-plating additive on the coefficient of friction and oil temperature was investigated through the tribological tests with motor and transmission oil without and with the additive.

Longevity of lubricating oil depends on the antioxidant property and the service properties during operation and storage. Increased temperature and air oxygen assist oil aging. Hence, lubricant oil antioxidation stability is most important for its service life. Less stability means also that it should be changed more often. During machine operation oil oxidation is intensified.

In order to reduce oil oxidation, metal-plating oil additives (realizing selective transfer of materials) were developed. One of the newest is the oil-soluble metal cladding additive *Valena*. V. Babel used inorganic salts, halides, as oil additives for improving tribological properties of the surfaces. As metal halides are insoluble in mineral oil, organic compounds were used to dissolve salts and give stable compositions when combined with oil. Alcohols meet these requirements. Alcoholic solutions of metal halides were injected into the base oil obtaining lubricant compositions. A negative influence of their acidity could cause corrosive effect, so industrial anticorrosive additive were also added into the compositions [1].

## APPLICATION OF VALENA ADDITIVE IN THE STUDY OF WEAR RESISTANCE OF HIGH STRENGTH CAST IRON

Examples referring to the study of wear under lubricated conditions illustrate the influence of the presence of *Valena* additive in the lubricant. Wear characteristics of high strength cast iron specimens were studied by the authors under conditions of lubricated friction without and with *Valena* additive.

*Experimental results: Influence of "Valena" additive on cast iron wear*

The high strength (steel metal matrix with embedded graphite phase) cast iron provides a complex of properties which make it different from the conventional Fe-C alloys. Its mechanical and tribological properties are strongly dependent on the composition, structure, and on the size and distribution of the graphite inclusion, as well as on the presence of micro-alloying elements both in bulk and surface layers [26].

Tin (Sn) is most often used as alloying element. The usual quantities of less than 0.15 % do not influence the leaning to graphite adoption in the crystallization process. Alloying of spheroid cast iron by Sn causes perlitization of the metal base, along with strength and hardness increase by decrease of the relative increment of collision resilience. This influences the parameters of friction and wear in the contact joints of machines [26].

The paper illustrates the additive influence on the wear of cylindrical specimens of high strength cast iron micro-alloyed by various mass percent contents of tin (Sn): 0 wt.% (reference); 0.018 wt.%; 0.020 wt.%; 0.032 wt.% and 0.051 wt.%, under lubricated conditions. Lubrication was provided with the transmission oil SAE 80W-90 without and with "Valena" additive. Test was carried-out on tribometer shown in Figure 2.

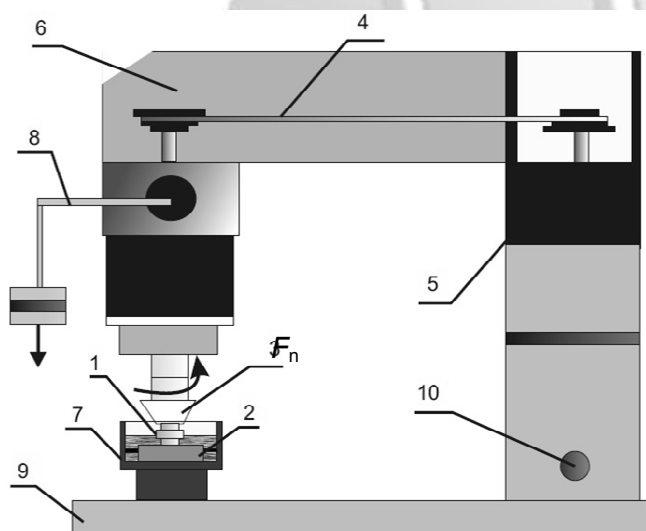

**Figure 2. Device for wear study under lubricated conditions: 1 - specimen; 2 - counter-body; 3 - specimen holder; 4 - belt; 5 - motor; 6 - case; 7 - lubricant tray; 8 - arm; 9 - footstall; 10 - motor switch**

The dimensions of the specimen and the counter-body are given in Figure 3. The working surface of all specimens was grinded to the roughness of  $R_a = 0.453 \mu\text{m}$ . The hardness of the tested specimens is given in Table 1.

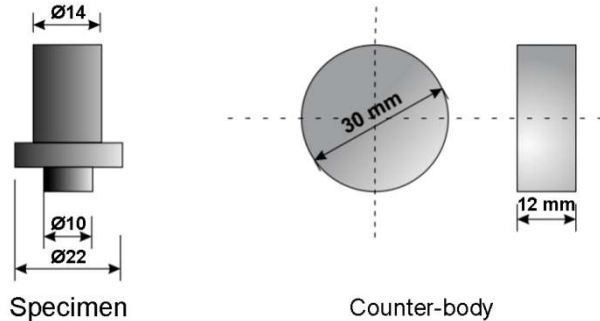

**Figure 3. Dimensions of the specimen and the counter-body**

**Table 1. Hardness of the tested specimens (materials)**

Sn, wt.%	0	0.018	0.020	0.032	0.051
Hardness HB	179	197	203	262	277

Parameters of the experiment were as follows: normal load  $F_n = 39.24 \text{ N}$ ; apparent contact area  $A_a = 78.54 \text{ mm}^2$ ; apparent contact pressure  $p = 0.5 \text{ MPa}$ ; peripheral sliding speed  $v = 0.26 \text{ m/s}$ ; test duration  $t = 30 \text{ minutes}$ ; counter-body material: Structural steel S460QL EN10025-6, heated at  $840^\circ\text{C}$  and cooled in oil up to 60HRC.

Mass loss of the specimens has been measured after the given sliding time (0, 20, 30, 40, 50 and 60 minutes) in order to construct the wear curves (Figures 4 and 5).

**Figure 4. Wear curves; lubricant oil SAE 80W-90 without "Valena" additive**

**Figure 5. Wear curves; lubricant oil SAE 80W-90 with "Valena" additive**

Wear curves of the tested materials were in correlation with the theoretical ones, i.e. the amount of worn material increased with the increasing of the sliding time. After initial period (running-in) the wear curves tends to stabilize, i.e. before the onset of the usually lower and linear steady-state wear, run-in wear appears as the initial high-rate transient wear.

The cast iron specimens without Sn alloying (0 wt.% Sn) showed the highest wear regardless of which lubricating oil was used (without or with additives).

Steady-state wear rate (the slope of the wear curve) was not calculated, but based on the Figures 4 and 5 it can be concluded that the increase of wt.% Sn content decrease the wear rate.

The influence of the “Valena” additive is shown on Figure 6. Mass losses at the end of test (total mass losses), i.e. after 60 minutes, are shown comparatively for both lubricating oils (without and with “Valena” additive). Tendency for all specimens was the same, i.e. the mass loss was much lower when the lubricating oil contained “Valena” additive.

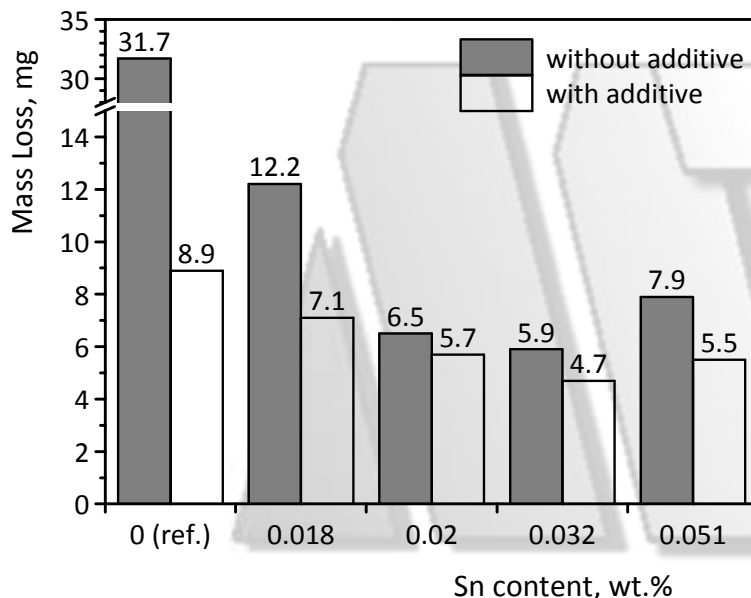

**Figure 6. Mass loss at the end of test (total mass loss) vs. Sn content; lubricant oil SAE 80W-90 without and with “Valena” additive**

## CONCLUSION

Review of the state-of-the-art in the tribological demands to wear prevention and modern lubricant development has been done. An illustration of a modern development of lubricants and additives is done by the studies of the oil-soluble metal-plating composite additive “Valena”, created and manufactured in Russia and Kazakhstan, and studied in the Tribology Laboratories at Faculty of Industrial Engineering, Technical University Sofia and Faculty of Mechanical Engineering, University of Belgrade.

Wear characteristics of high strength cast iron specimens were studied under lubricated conditions by using transmission oil without and with “Valena” additive. The results have shown that the wear values, for all specimens, are lower in the case of oil that contain “Valena” additive. The obtained



results stimulate a future systematic study of the influence of this additive in tribosystems operating under various conditions and with various characteristics.

The importance of environmental engineering through the sustainable tribology solutions should show that sustainability can be achieved to a significant extent through the sustainable and environmental friendly engineering solutions stimulating and providing stability to our world. The wear process limits the lifetime of machinery and equipment components, leads to high consumption of natural resources, and causes environment contamination. So, a task of primary importance appears to be the *minimization of wear*. Surface coatings are successful technology to wear prevention and reduction, next to the development of modern lubricants and additives, with an important example being the application of “Valena” additive. Implementation of the progressive tribological technologies is of major significance for quality, reliability and life of the systems and for the environmental friendly development of our societies. This implementation needs educational and research work, and a new way of thinking for the future.

#### ACKNOWLEDGEMENT

This study embraces the completion of tasks under the following projects: (a) International cooperation agreement between the Faculty of Industrial Technology at TU-Sofia and the Faculty of Mechanical Engineering at the University of Belgrade; (b) Completion of a PhD dissertation at the TU – Sofia; (c) Program for scientific-technological collaboration of the Tribology center in TU-Sofia and the company “Rudservice” from Gezkazgan, Kazakhstan; (d) Stage 2 of the first tribological network under CEEPUS project CIII-BG-0703 “Modern Trends in Education and Research on Mechanical Systems – Bridging Reliability, Quality and Tribology”; (e) Projects TR 34028 and TR 35021, supported by the Republic of Serbia, Ministry of Education, Science and Technological Development.

#### REFERENCES

- [1] D.N. Garkunov, *No-wear Effect under Friction: Hydrogen Wear of Metals*, MAA Publishing House, Moscow (Russia), 2007.
- [2] G. Polzer, *Der Erfahrungsaustausch: Reibbeschichten und selective Uebertragung*, Publ. Bezirks-Neuerer-Zentrum, Gera (Germany), 1988.
- [3] G. Polzer, E. Assenova, D. Tsermaa, *Copper frictional coatings under conditions of selective transfer*, Tribological Journal BULTRIB, 3 (2012), 197-202.
- [4] E. Assenova, G. Polzer, D. Tsermaa, M. Kandeve, The effect of selective transfer of materials between tribological surfaces, *Proceedings of the 19<sup>th</sup> International Colloquium: Tribology – Industrial and Automotive Lubrication*, 21-23.01.2014, Stuttgart, Germany, Paper 09\_05 (Session B-3: Surface Description and Tribological Behaviour 2).
- [5] M. Kandeve, A. Vencl, E. Assenova, Influence of “Valena” metal-plating additive on the friction properties of ball bearings, Tribological Journal BULTRIB, 4 (2014), 18-24.
- [6] Antifrictional metal-plating lubricant, Patent/221/2219225, Russia; <http://www.findpatent.ru/patent/221/2219225.html>, and Metal-containing oil-soluble composition for lubricating materials, Patent/227/2277579, Russia; <http://www.findpatent.ru/patent/227/2277579.html>.

- [7] H.P. Jost, Tribology: How a word was coined 40 years ago, *Tribology & Lubrication Technology*, (2006) 3, 24-28.
- [8] C. Kajdas, S.S.K. Harvey, E. Wilusz, *Encyclopaedia of Tribology*, Elsevier, Amsterdam (Netherlands), 1990.
- [9] M. Nosonovsky, B. Bhushan, Green tribology: principles, research areas and challenges, *Philosophical Transactions of the Royal Society A*, 368 (2010), 4677-4694.
- [10] W.J. Bartz, Ecotribology: Environmentally acceptable tribological practices, *Tribology International*, 39 (2006) 8, 728-733.
- [11] S. Sasaki, Environmentally friendly tribology (Eco-tribology), *Journal of Mechanical Science and Technology*, 24 (2010) 1, 67-71.
- [12] E. Assenova, V. Majstorovic, A. Vencl, M. Kandeve, Green tribology and quality of life, *Advanced Quality*, 40 (2012) 2, 26-32.
- [13] K. Holmberg, A. Mathew, *Coatings Tribology: Properties, Mechanisms, Techniques and Applications in Surface Engineering*, Elsevier, Amsterdam (Netherlands), 2009.
- [14] I.V. Kragelsky, *Friction and Wear*, Mashinostroenie, Moscow (Russia), 1968, (in Russian; available also in English).
- [15] B. Bhushan (Ed.), *Modern Tribology Handbook*, CRC Press, Boca Raton (USA), 2001.
- [16] H.P. Jost, Tribology – From basics to productivity and employment, Opening Speech at the 5<sup>th</sup> World Tribology Congress (WTC 2013), 08-13.09.2013, Turin, Italy.
- [17] W.J. Bartz, Reducing the impairment of the environment, *Proceedings of the 2<sup>nd</sup> European Conference on Tribology ECOTRIB 2009*, 07-10.06.2009, Pisa, Italy.
- [18] J. Van Rensselar, 10 trends shaping tomorrow's tribology, *Tribology & Lubrication Technology*, (2014) 2, 26-35.
- [19] A. Rac, A. Vencl, Ecological and technical aspects of the waste oils influence on environment, *Proceedings of the 3<sup>rd</sup> International Conference on Diagnosis and Prediction in Mechanical Engineering Systems – DIPRE '12*, 31.05-01.06.2012, Galați, Romania, Paper 6 (Session: Lubrication and Lubricants).
- [20] R.M. Mortier, M.F. Fox, S.T. Orszulik (Eds.), *Chemistry and Technology of Lubricants*, Springer, Dordrecht (Netherlands), 2010.
- [21] --, *Global Lubricants Market 2017*, <http://www.prweb.com/releases/global-lubricants-market/2017-forecast/prweb10992306.htm>
- [22] A. Rac, A. Vencl, Lj. Savić, Stanje tržišta maziva u svetu – pogled na tržište Srbije, *Proceedings of the 10<sup>th</sup> International Conference on Tribology – SERBIATRIB '07*, 19-21.06.2007, Kragujevac, Serbia, 193-196, (in Serbian).
- [23] A. Rac, A. Vencl, Performance investigation of chain saw lubricants based on new sunflower oil (NSO), *Tribologie und Schmierungstechnik*, 56 (2009) 3, 51-54.
- [24] W.J. Bartz, Lubricants and the environment, *Tribology International*, 31 (1998) 1-3, 35-47.
- [25] M.D. Rogers, The use of copper to prevent scuffing in diesel engines, *Wear*, 22 (1972) 2, 245-257.
- [26] M. Kandeve, B. Ivanova, Abrasive wear and wear-resistance of high strength cast iron containing Sn microalloy, *Proceedings of the 13<sup>th</sup> International Conference on Tribology – SERBIATRIB '13*, 15-17.05.2013, Kragujevac, Serbia, 26-30.