

Tribological studies on copper-based friction linings

M. Kandeveva^a, D. Karastoyanov^b, G. Nikolcheva^a, B. Stojanović^c, P. Svoboda^d, A. Vencle^e

^aFaculty of Industrial Technology, Technical University of Sofia, 8 Kliment Ohridski Blvd, 1000 Sofia, Bulgaria,

^bInstitute of Information and Communication Technologies, Bulgarian Academy of Sciences, Acad. Georgi Bonchev St., Block 2, 1113 Sofia, Bulgaria,

^cUniversity of Kragujevac, Faculty of Engineering, Sestre Janjić 6, 34000 Kragujevac, Serbia,

^dFaculty of Mechanical Engineering, Brno University of Technology, Technická 2896/2, 616 69 Brno, Czech Republic,

^eUniversity of Belgrade, Faculty of Mechanical Engineering, Kraljice Marije 16, 11120 Belgrade 35, Serbia.

Keywords:

Friction couplings

Copper

Tin

Silicon carbide

Friction

Abrasive wear

ABSTRACT

The objects of this work were nine different copper-based friction linings produced from powder by pressing and sintering. Six copper-based friction linings contained 3 wt.% zinc (Zn) and variable content of tin (Sn), i.e. 1, 2, 4, 6, 8 and 10 wt. %. Three copper-based friction linings were with fixed contents of Zn (3 wt.%) and Sn (10 wt.%), and with different amount of SiC particles, i.e. 2, 4 and 6 wt.%. Tribological studies on these friction linings included determination of the static and kinetic coefficient of friction under different normal loads and unlubricated sliding conditions, as well as, determination of the abrasive wear resistance under different normal loads and unlubricated sliding/rolling conditions. The analysed results present the influence of Sn content and addition of SiC particles to the copper-based friction lining on its friction and wear properties.

© 2017 Published by Faculty of Engineering

Corresponding author:

Mara Kandeveva

Faculty of Industrial Technology,
Technical University of Sofia,
8 Kliment Ohridski Blvd, 1000 Sofia,
Bulgaria

E-mail: kandevam@gmail.com

1. INTRODUCTION

Multiple-disc clutches (Fig. 1) are type of friction couplings which transmit motion and torque over the multiple friction plates (discs). They are used primarily in machine tools gearboxes, but also in the textile, construction and other machinery [1]. They also can be used as brakes. A multiple-disc clutch or brake is composed of friction lining discs and steel discs, which are internally or externally toothed and which upon activation are pressed against one another and transmit frictional torque [2]. By using multiple

discs, a very large contact surface is obtained and more friction is achieved. Contact between the discs may be without or with lubrication, i.e. dry and wet clutches.

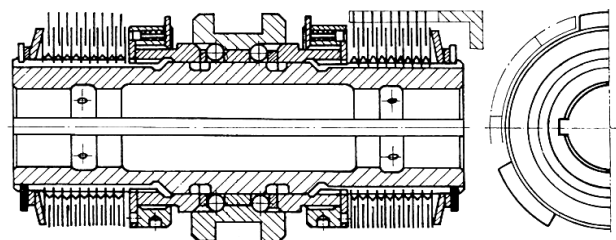

Fig. 1. Schematic diagram of multiple-disc clutch

The friction materials (friction linings) must pose a complex of diverse and in many cases mutually exclusive properties. They should have high coefficient of friction, high wear resistance and resistance to seizure, high thermal conductivity, high strength, good processing and machinability, high corrosion resistance, etc. Depending on the application and requirements, very different friction linings are used, i.e. organic friction linings (paper-based linings), metal friction linings (sintered bronze, iron and brass), carbon and carbon-containing friction linings, and ceramic and ceramic-containing friction linings [2,3].

The powder metal friction linings (sintered bronze, iron and brass) are based on a sintered metal matrix, into which mineral, metallic, non-metallic or ceramic agents, as well as abrasives and solid lubricants can be embedded. The production of powder metal friction linings includes compaction (densification) of powder and sintering. During sintering processes powder mixtures are heated to temperatures below the melting point, under pressure and controlled protective atmosphere. Thereby annealing, diffusion and recrystallization processes occur. These friction linings can be considered as mechanical coatings (solid state surfacing) [4], since the lining (coating) are bonded during sintering to the steel disc (substrate). Copper and iron are the most frequently used as the main metals forming the matrix of sintered materials for friction purposes [5]. Iron-based friction material has high temperature strength, hardness and thermal stability, while copper-based friction material has smaller but more stable coefficient of friction [6]. There is also a rapid increase in interest in composites as a promising class of friction materials [7].

The aim of this paper was to investigate the possibilities to increase the service life and coefficient of friction of multiple-disc clutches with copper-based friction linings. Relative to this, the influence of Sn content and addition of SiC particles to the copper-based friction lining on its friction and wear properties were investigated. All together nine different copper-based friction lining materials were tested, i.e. their static and kinetic coefficient of friction and abrasive wear resistance in unlubricated conditions were analysed.

2. EXPERIMENTAL DETAILS

2.1 Materials

The substrate material for all copper-based friction linings was a high-carbon steel, in form of circular discs, with chemical composition shown in Table 1. Outer diameter of all circular discs was 89 mm, inner diameter was 60 mm, and thickness was 1.5 mm. Nine different copper-based powder mixtures were compacted and sintered on steel disc substrates. Their chemical composition is shown in Table 2. The powder mixtures were prepared by ball milling at 200 rpm for 90 minutes. After ball milling, the average particle size was 25 μm . All copper-based friction linings were compacted at a pressure of 320 MPa, and sintered at a temperature of 700 $^{\circ}\text{C}$ for 3 hours. Designation and hardness of the friction lining samples is shown in Table 2.

Table 1. Designation, chemical composition (wt. %) and hardness of tested friction lining samples.

Sample designation	Powder chemical composition [wt.%]				Hardness HB	
	Zn	Sn	SiC	Cu		
Cu-1Sn	3	1	-	Balance	75.5	
Cu-2Sn		2			76.2	
Cu-4Sn		4			81.5	
Cu-6Sn		6			84.4	
Cu-8Sn		8			89.2	
Cu-10Sn		10			94.0	
Cu-10Sn-2SiC		10			2	125
Cu-10Sn-4SiC					4	138
Cu-10Sn-6SiC					6	144

Table 2. Chemical composition (wt.%) of steel disc substrate.

Element	C	Si	Mn	Ni	P	S	Cr	Fe
Percentage	0.7	0.28	1.1	0.18	0.03	0.02	0.25	Balance

The thickness of friction linings was measured in 10 points by Pocket-LEPTOSKOP 2021 Fe, and the calculated average thickness of 150 μm was the same for all samples.

2.2 Coefficients of friction testing

The coefficient of friction testing was performed on the test rig presented in Fig. 2. Test sample (1) is mounted and fixed in the sample holder (3), which is connected through the non-elastic string with the dynamometer (6). Tangential

force (T) is loaded to the sample through the very slow rotation of the micrometric screw (5) and displayed on the dynamometer (6). The counter-body (2) is stationary and in contact with the test sample (1). The normal force (F_n) is set by means of the weights (4). The test rig shown in Fig. 2 enables determination of the two values, i.e. static and kinetic coefficient of friction. Both values are read from the same dynamometer (position 6 in Fig. 2).

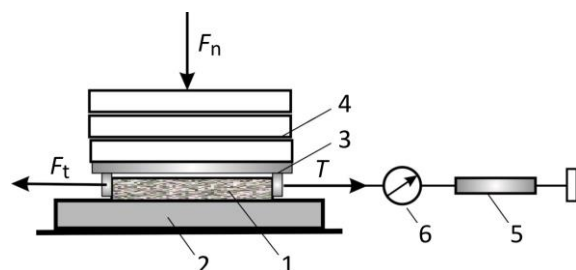

Fig. 2. Schematic diagram of the coefficients of friction testing.

Test parameters were as follows: four different normal loads, i.e. 40, 80, 120 and 160 N; dry contact condition, in ambient air at room temperature ($\approx 25\text{ }^\circ\text{C}$) and relative humidity of 40 – 45 %. Test sample and counter-body were in the shape of circular disc with outer/inner diameter of 89/60 mm (Fig. 3). This gives the initial geometrical contact area of approximately 3394 mm². Taking into account this contact area, the specific loads were approximately 12, 24, 35 and 47 kPa. The resting time (time for the possible stress relaxation at the junctions) was 30 s for each contact pair.

2.3 Abrasive wear testing

Abrasive wear testing was carried out on Taber Abraser with a modified standard test conditions, i.e. only one abrasive roller was used (Fig. 4). A circular disc (1), having outer/inner diameter of 89/60 mm, with friction lining sample (2) is fixed on the horizontal turntable platform, driven with constant rotational speed (n) of 60 rpm by the electric motor (3). Abrasive roller (4), a Taber abrading wheel Calibrase® CS-10, is mounted on horizontal axis (5) and provides through weights (6) the necessary normal load (F_n). Abrasive wear of friction lining samples is calculated as their mass loss, i.e. as a difference between the initial mass of the sample and its mass after given number of abrasion cycles (N), counted by the counter (pos. 7 in Fig. 4). Mass of the samples is measured by the electronic balance with accuracy of 0.1 mg.

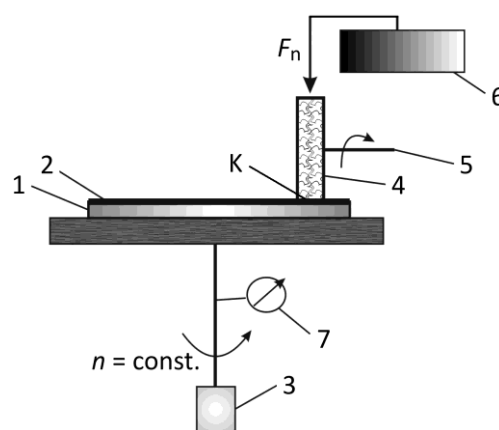

Fig. 4. Schematic diagram of the abrasive wear testing.

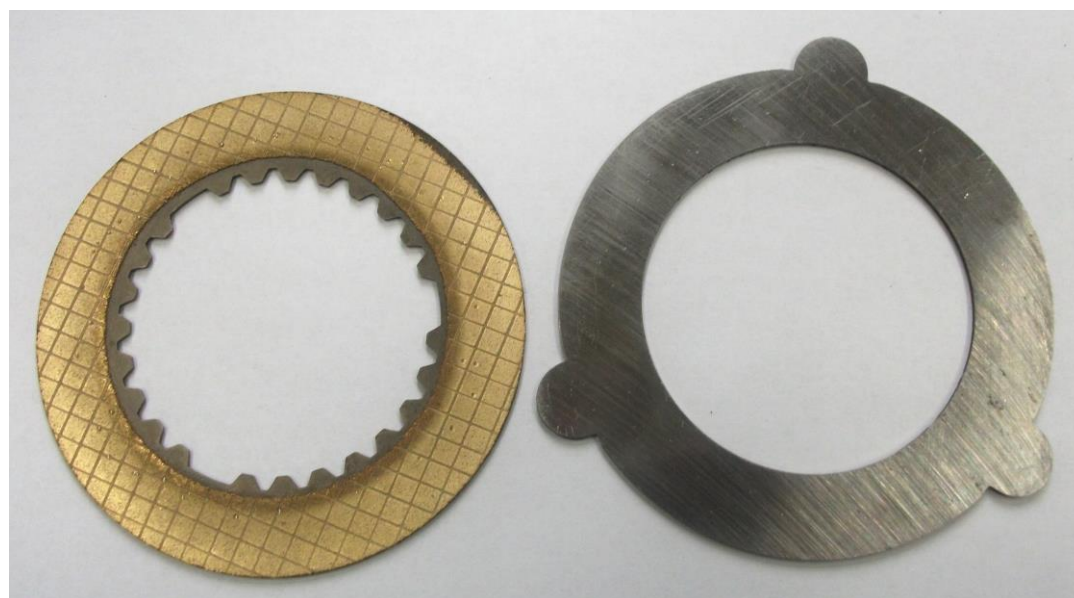

Fig. 3. Appearance of the copper-based friction lining test sample (left) and the steel counter-body (right).

Abrasive roller (wheel) is driven by the rotating test sample. The wheels produce abrasion marks that form a pattern of crossed arcs over a circular ring. The width of the worn area (circular ring) is 12.7 mm, with the inner radius of 31.75 mm and outer radius of 44.45 mm (Fig. 5). Therefore, the distance between the rotational axis of circular disc sample (1) and mass centre of the contact area (K) is 38.1 mm, and the worn area is approximately 30 cm² [8]. The sliding action between the friction lining sample and abrasive roller is due to the relative motion between them which is characterised by the roller slip. This occurs because the axe of the roller is shifted from the centre of rotation of circular disc sample with the drifting angle of around 30° [9].



Fig. 5. Wear track (lighter circular ring) on sample Cu-4Sn after 300 abrasion cycles (approx. 71.8 m).

Test parameters were as follows: normal load of 1 kg (9.8 N); average tangential velocity of friction lining sample of 0.239 m/s; sliding distance of $N = 400$ abrasion cycles (approx. 95.8 m); dry contact condition, in ambient air at room temperature (≈ 25 °C) and relative humidity of 40 – 45 %.

3. RESULTS AND DISCUSSION

3.1 Static and kinetic coefficient of friction

The obtained values of the coefficients of friction are presented in Fig. 6. Values were in the range 0.22 – 0.34 for static coefficient of friction, and

0.15 – 0.32 for kinetic coefficient of friction. These values more or less correspond to the values for sintered friction clutch materials under dry sliding conditions, which are 0.36 (static coefficient of friction) and 0.30 (kinetic coefficient of friction) [10]. The average coefficient of friction of modern friction materials is between 0.3 and 0.5 [11]. In our case, contact pressure was very small (from 12 to 47 kPa) and that could be the reason for smaller values of the coefficients of friction.

It is well known that the friction depends on the size of actual (real) contact area. The number and size of the contact point will increase with the increasing pressure. If the contact between asperities is elastic, the coefficient of friction will decrease with the increasing pressure. On the other hand, if the contact between asperities is plastic, the coefficient of friction will increase with the increasing pressure. In general case the coefficient of friction dependence on load possesses the minimum that is connected directly with transition from elastic to plastic contact (when load is increasing) and associated variation in the relative contribution of the friction components [12]. In fact, something similar can be noticed on Fig. 6, which shows the influence of normal load on both, static and kinematic coefficient of friction. Both coefficients of friction, for all materials, mainly decrease as the normal load increase up to 80 N, and after that load starts mainly to increase.

Differences between static and kinetic coefficient of friction did not differ too much between the samples. On the other hand, this difference changes with applied normal load. The average decrease of kinetic comparing to static coefficient of friction was 0.08 (31.2 %) for loads of 40 and 80 N, while for 100 and 120 N loads this average decrease was 0.03 (9.7 %). Static coefficient of friction is usually greater than kinetic coefficient of friction of about 20 to 30 % [13]. When the static coefficient of friction is noticeably greater than the kinematic one, the phenomenon of stick-slip may occur, which is not desirable in terms of continuous torque transmission in friction couplings. This is due to the fact that before the onset of motion, a large stress relaxation at the junctions may occur, which causes an increase in the real area of contact and allows the adhesive forces to fully develop. This is particularly important in the

contact that are mostly plastic and when the sliding surfaces are without contaminants [13].

Influences of tin (Sn) content and silicon carbide (SiC) particles content on the static and kinetic coefficients of friction are analysed separately. Based on the results given in Fig. 6, appropriate diagrams are drawn for the dependences of coefficients of friction on Sn content (Fig. 7), and on SiC particles content (Fig. 8), for different loads. Once again, different behaviour is noticed for lower loads and for higher loads. Generally,

both static and kinetic coefficient of friction are higher when the amount of Sn in copper-based friction lining is higher, but this influence is very small or do not exist at all for lower normal loads (Fig. 7). For higher loads this influence can not be neglected. As example, friction linings with 8 and 10 wt.% Sn, at highest applied load of 160 N, show the highest values. Their static coefficient of friction is higher by 0.07 (29.2 %) and kinetic coefficient of friction is higher by 0.10 (50.0 %), comparing to the friction lining with 2 wt.% Sn at the same load.

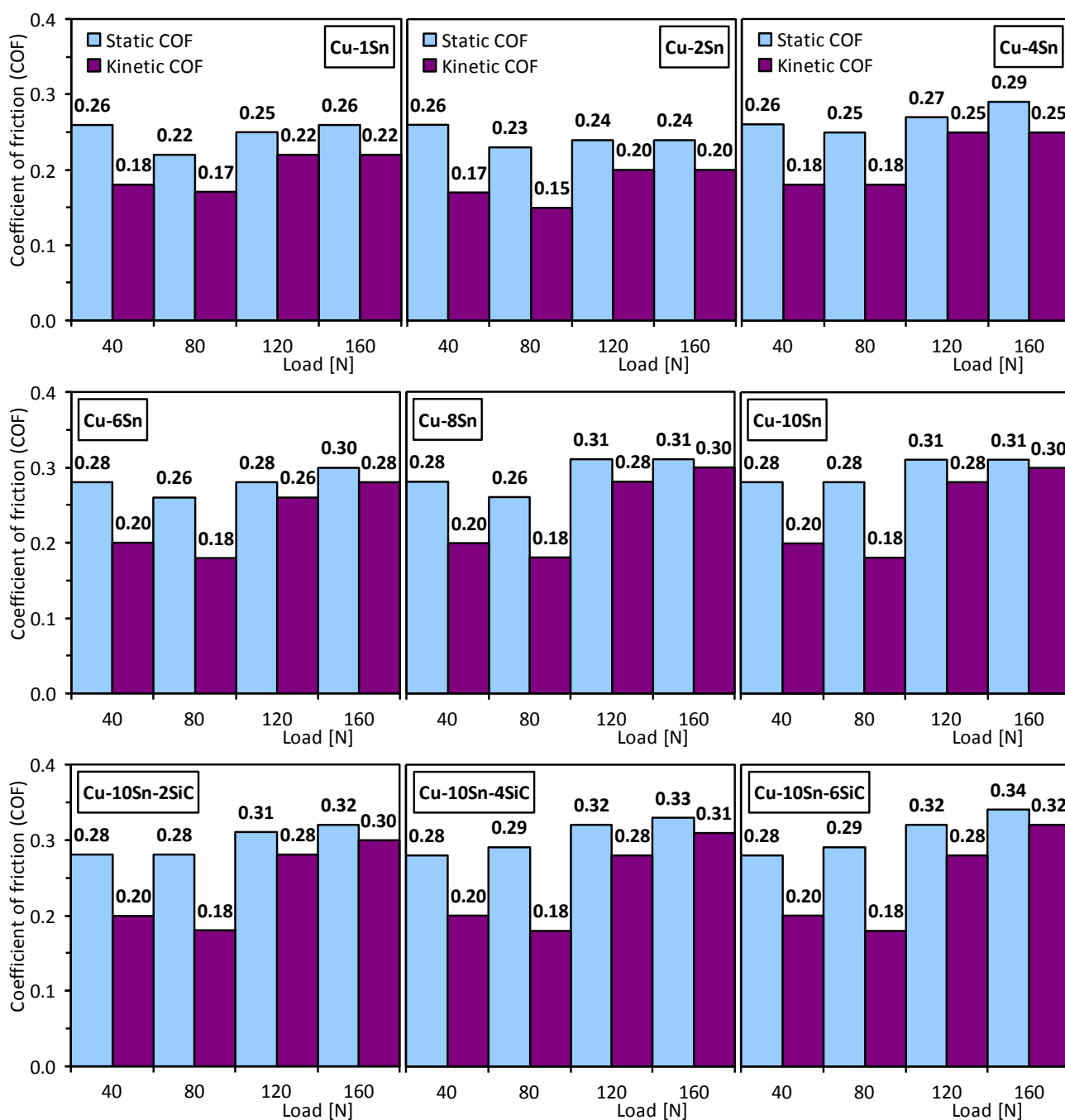

Fig. 6. Static and kinetic coefficient of friction of tested materials (contact pairs) for different loads: Influence of load on coefficients of friction values.

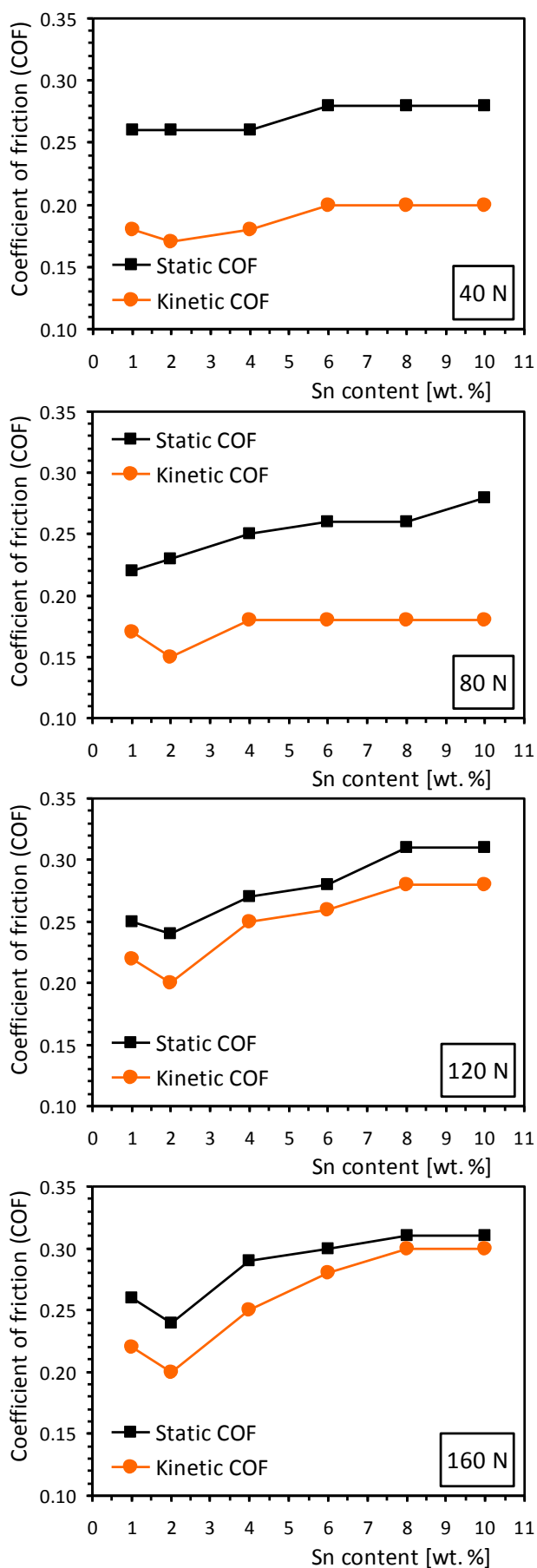

Fig. 7. Dependence of static and kinetic coefficient of friction on Sn content, for different normal loads.

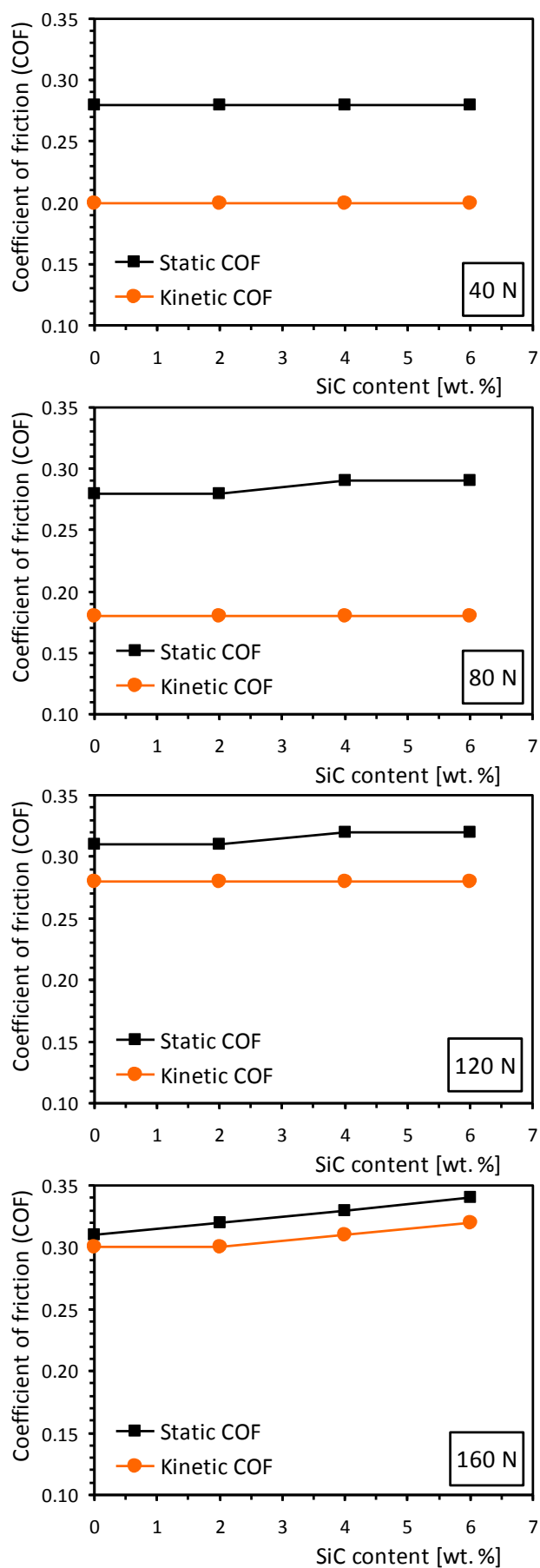

Fig. 8. Dependence of static and kinetic coefficients of friction on SiC content, for different normal loads.

Similarly, addition of SiC particles to copper-based friction linings did not influence in significant manner the values of the coefficients of friction at lower loads (Fig. 8). The more significant increase of coefficients of friction is noted only at the highest load of 160 N. At this load the highest values of coefficients of friction were for the friction lining containing the biggest amount of SiC particles (Cu-10Sn-6SiC). Static coefficient of friction of this friction linings at load of 160 N is higher by 0.03 (9.7 %) and its kinetic coefficient of friction is higher by 0.02 (6.7 %), comparing to the friction lining without SiC particles at the same load. Based on the percentage increase at 160 N load, it can be concluded that the addition of Sn has bigger influence on coefficients of frictions values than the addition of SiC particles.

If we analyse the mutual effect of Sn and SiC particles addition, the increase of the coefficients of friction is even higher. This is obtained by comparing friction lining which showed the highest values of coefficients of friction (Cu-10Sn-6SiC) with the friction lining which showed the lowest values of coefficients of friction (Cu-2Sn). In this case, at load of 160 N, the increase of static coefficient of friction of 0.10 (41.7 %), and kinetic coefficient of friction of 0.12 (60.0 %) is obtained.

3.2 Abrasive wear resistance

Abrasive wear of the friction linings was determined at various number of cycles, i.e. at N = 100, 200, 300 and 400, which corresponds to the following sliding distances: 23.9, 47.9, 71.8 and 95.8 m. Obtained mass losses for each number of cycle/sliding distance are presented in Table 3.

Table 3. Abrasive wear of tested friction linings

Sample designation	Number of cycles (N)			
	100	200	300	400
	Sliding distance [m]			
	23.9	47.9	71.8	95.8
	Mass loss [mg]			
Cu-1Sn	15.8	25.4	44.1	53.8
Cu-2Sn	14.8	16.6	33.2	36.2
Cu-4Sn	11.6	16.0	19.4	31.1
Cu-6Sn	12.8	14.7	27.7	29.2
Cu-8Sn	12.9	21.9	27.8	28.6
Cu-10Sn	12.0	23.8	24.5	25.0
Cu-10Sn-2SiC	10.0	14.6	18.5	20.1
Cu-10Sn-4SiC	8.0	12.2	16.8	18.1
Cu-10Sn-6SiC	5.0	10.2	14.8	16.1

Using the results from Table 3, mass losses are shown as a function of sliding distance, in the form of comparative wear curves (Fig. 9). The appearance of the constructed wear curves is similar for all tested friction linings, i.e. more or less linear dependence of wear on sliding distance is noticed. This suggests that the steady-state wear occurs from the beginning of the tests, which is common thing for the abrasive wear.

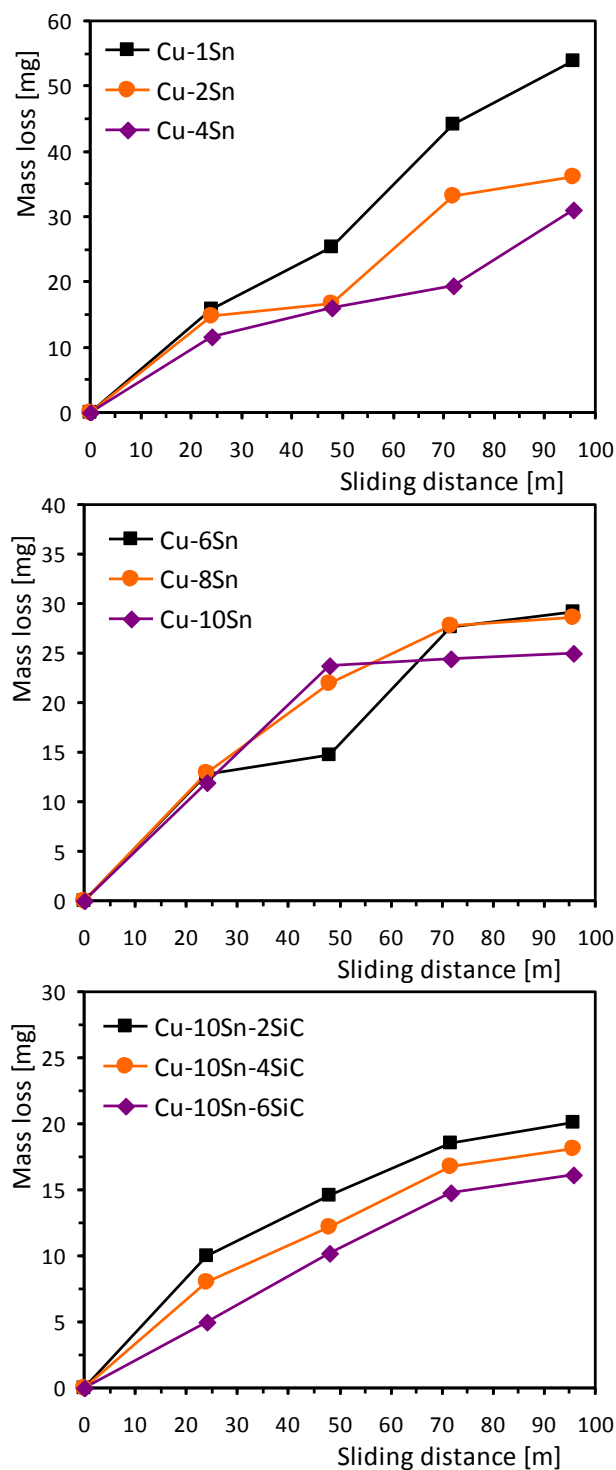

Fig. 9. Mass loss vs. sliding distance (wear curves) for tested friction linings.

In order of easier comparison of different friction linings and influences of Sn and SiC particles content, values of total wear rates are calculated and presented in Figs. 10 and 11. Total wear rates were calculated by using the highest mass losses and sliding distances, assuming that the steady-state wear occurred from the beginning of the tests. In addition to the wear data, the hardness of each of tested friction linings was determined (Table 2), as an ancillary mechanical property, to make appropriate correlations (Figs. 10 and 11).

The analysis of the results show that the presence of higher amount of tin (Sn) decreases the abrasive wear of tested friction linings (Fig. 10). The lowest wear rate of 2.61×10^{-1} mg/m shows sample Cu-10Sn, i.e. friction lining with the highest amount of Sn (10 wt.%). The

increase of wear resistance for this friction lining is approximately 2.2 times in comparison to friction lining Cu-1Sn (sample with the lowest amount of Sn of 1 wt.%) which shows the highest wear rate of 5.62×10^{-1} mg/m.

Presence of silicon carbide (SiC) particles also decreases the abrasive wear of tested friction linings, and this decrease is higher as the amount of SiC particles increases (Fig. 11). The lowest wear rate of 1.68×10^{-1} mg/m shows sample Cu-10Sn-6SiC, i.e. friction lining with the highest amount of Sn (10 wt.%) and highest amount of SiC particles (6 wt.%). The increase of wear resistance for this friction lining is approximately 1.6 times in comparison to friction lining Cu-10Sn (sample with the same amount of Sn and without SiC particles) which shows the wear rate of 2.61×10^{-1} mg/m.

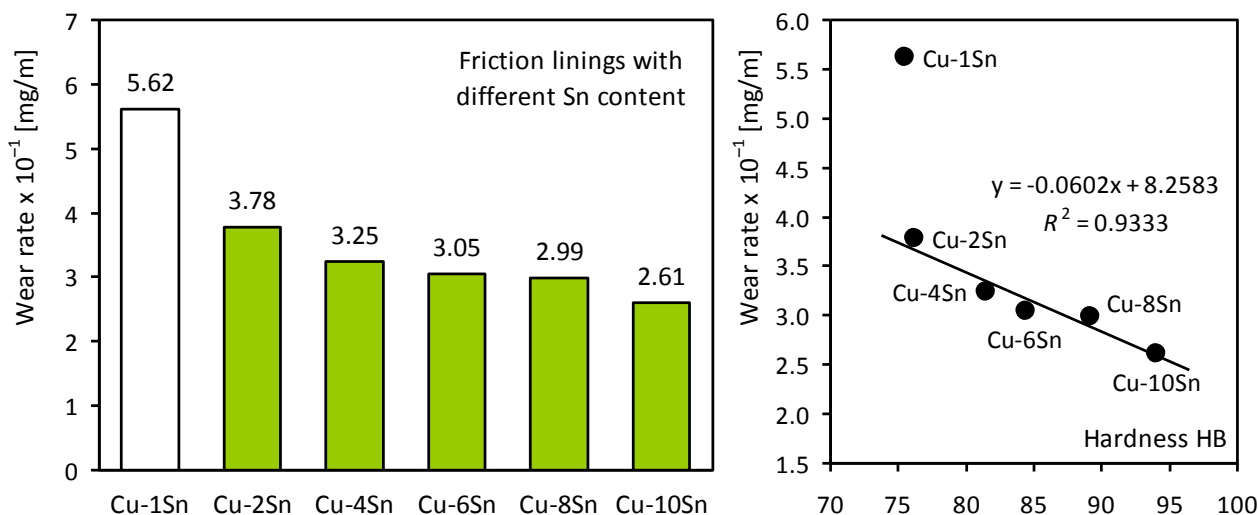

Fig. 10. Friction linings with different content of Sn: total wear rates (left) and dependence of abrasive wear rate on hardness (right).

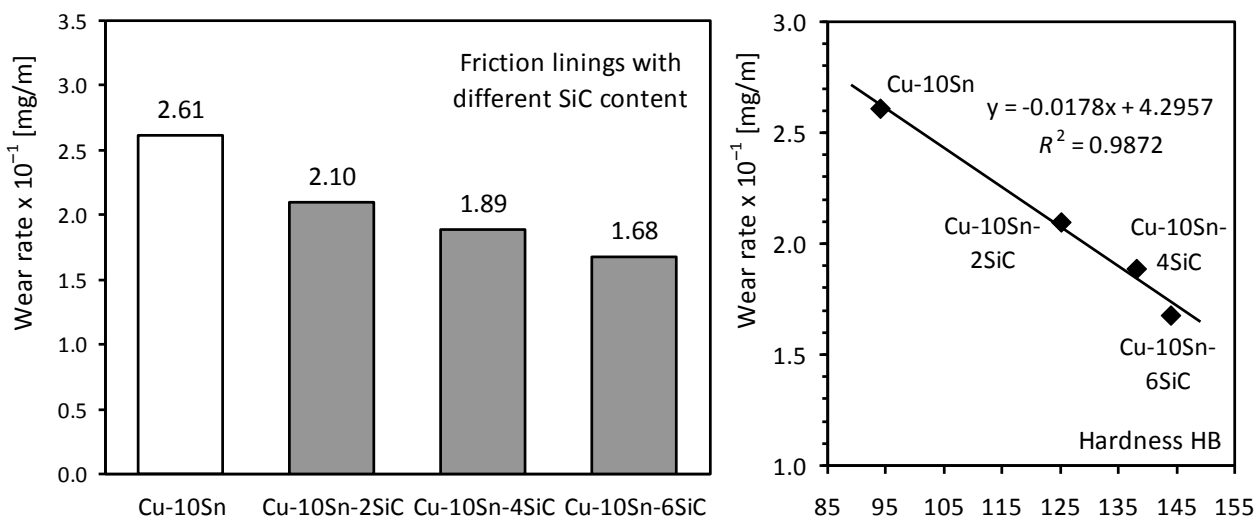

Fig. 11. Friction linings with different content of SiC particles: total wear rates (left) and dependence of abrasive wear rate on hardness (right).

If we analyse the mutual effect of Sn and SiC particles addition, the increase of the wear resistance is even higher. This is obtained by comparing friction lining which had the lowest wear rate (Cu-10Sn-6SiC) with the friction lining which had the highest wear rate (Cu-1Sn). In this case, increase of wear resistance of approximately 3.3 times is obtained.

The noticed decrease of wear rate with the increase of Sn and SiC particles content is connected with hardness of the tested samples. The wear rate decreases as hardness increase, as it could be expected. The relationships between obtained abrasive wear values and hardness (Table 2) of tested friction linings are shown in Figs. 10 and 11. The obtained correlations between wear rate and hardness of tested samples are almost linear, with the exception of sample Cu-1Sn. Indeed, the other friction linings showed good correlation, since the R-squared (R^2) value are relatively high ($R^2 = 0.93$ for samples without SiC particles and $R^2 = 0.99$ for samples with SiC particles).

4. CONCLUSIONS

In this study, the friction and wear behaviour of nine different copper-based friction linings, produced from powder by pressing and sintering, were investigated. Different samples were obtained by varying the amount of Sn (1, 2, 4, 6, 8 and 10 wt.%) and SiC particles (0, 2, 4 and 6 wt.%) in friction linings.

Generally, both static and kinetic coefficients of friction are higher when the amount of Sn in copper-based friction lining is higher, but this influence is very small or do not exist at all for lower normal loads. For higher loads this influence can not be neglected. Similarly, addition of SiC particles to copper-based friction linings did not influence in significant manner the values of the coefficients of friction at lower loads, but only at the highest applied load. The analysis of the wear results show that the presence of higher amount of Sn decreases the abrasive wear of tested friction linings. Presence of SiC particles also decrease the abrasive wear of tested friction linings, and this decrease is higher as the amount of SiC particles increases.

The highest values of static and kinetic coefficient of friction and the lowest wear rate

showed friction linings with the highest amount of Sn (10 wt.%) and SiC particles (6 wt.%). It was shown that with mutual effect of Sn and SiC particles addition, tribological characteristic can be increased up to 1.6 times (kinetic coefficient of friction) and up to 3.3 times (wear resistance).

Acknowledgements

This work has been performed as a part of activities within the following projects: (a) Contract: ДН 07/28-15.12.2016 "Research and creation of new wear-resistant coatings using composites and nanomaterials", funded by the National Science Fund of the Ministry of Education and Science, Bulgaria; (b) CEEPUS III Network: CIII-BG-0703; (c) Projects TR 34028 and TR 35021, supported by the Republic of Serbia, Ministry of Education, Science and Technological Development; (d) Project LO1202, funded by the Ministry of Education, Youth and Sports (MEYS) of Czech Republic, under the National Sustainability Programme I.

REFERENCES

- [1] M. Puljizević, *Spojnice*, in Z. Savić (Ed.): *Inženjersko mašinski priručnik, knjiga II*. Zavod za udžbenike i nastavna sredstva, Beograd, pp. 343-377, 1987.
- [2] D. Frey, *Wet multi disk clutches and brakes*, in T. Mang (Ed.): *Encyclopedia of Lubricants and Lubrication*. Springer, Berlin, pp. 2347-2362, 2014.
- [3] J.Y. Jang and M.M. Khonsari, *Wet clutch friction material: The surfaced groove effect*, in Q.J. Wang and Y.-W. Chung (Eds.): *Encyclopedia of Tribology*. Springer, New York, pp. 4102-4108, 2013.
- [4] M. Kandeve-Ivanova, A. Vencl and D. Karastoyanov, *Advanced Tribological Coatings for Heavy-Duty Applications: Case Studies*. Sofia: Prof. Marin Drinov Publishing House of Bulgarian Academy of Sciences, 2016.
- [5] V.M. Kryachek, 'Friction composites: Traditions and new solutions (review). I. Powder materials', *Powder Metallurgy and Metal Ceramics*, vol. 43, no. 11, pp. 581-592, 2004.
- [6] X. Xiao, Y. Yin, J. Bao, L. Lu and X. Feng, 'Review on the friction and wear of brake materials',

Advances in Mechanical Engineering, vol. 8, no. 5, pp. 1-10, 2016.

- [7] V.M. Kryachek, 'Friction composites: Traditions and new solutions (review). II. Composite materials', *Powder Metallurgy and Metal Ceramics*, vol. 44, no. 1, pp. 5-16, 2005.
- [8] Taber Abraser (abrader), available at: <http://www.taberindustries.com/taber-rotary-abraser>, accessed: 10.04.2017.
- [9] E. Csanády, E. Magoss and L. Tolvaj, *Quality of Machined Wood Surfaces*. Cham: Springer International, 2015.
- [10] T.P. Newcomb, R.T. Spurr and H.C. Town, *Friction clutches*, in M.J. Neale (Ed.): *The Tribology Handbook*. Butterworth-Heinemann, Oxford, pp. B7.1-B7.9, 1995.
- [11] H. Heisler, *Brake system*, in H. Heisler: *Advanced Vehicle Technology*. Butterworth-Heinemann, Oxford, pp. 450-509, 2002.
- [12] Н.К. Мышкин and М.И. Петроковец, *Трение, смазка, износ*. Москва: Физматлит, 2007.
- [13] G. Straffelini, *Friction and Wear: Methodologies for Design and Control*. Cham: Springer, 2015.